



PT3200i 3000W DIGITAL INVERTER GENERATOR



OPERATING INSTRUCTIONS

Contents

| | |
|-------------------------------------|----|
| Symbol Usage | 6 |
| General Safety Precautions | 6 |
| Generator Controls & Features | 12 |
| Control Panel | 13 |
| Operation | 14 |
| Maintenance | 20 |
| Troubleshooting | 26 |
| Wattage Reference Guide | 27 |
| Calculating Your Power Needs | 28 |
| Wiring Diagram..... | 32 |
| Warranty..... | 37 |
| Notes..... | 38 |

Introduction

Your new POWERTEC Generator will more than satisfy your expectations. It has been manufactured under stringent quality standards to meet superior performance criteria. You will find your new tool easy and safe to operate, and, with proper care, it will give you many years of dependable service.

Carefully read through this entire Instruction Manual before using your new POWERTEC Generator. Take special care to heed the cautions and warnings.

Your generator has many features that will make your job faster and easier. Safety, performance, and dependability have been given top priority in the development of this tool, making it easy to maintain and operate.

Environmental Protection

Recycle unwanted materials instead of disposing of them as waste. All tools, hoses and packaging should be sorted, taken to the local recycling centre and disposed of in an environmentally safe way.



Scope Of Product

This product is suited for home, camping and emergency power applications. It will operate most powertools, appliances and lighting.

Description Of Symbols

The rating plate on your tool may show symbols. These represent important information about the product or instructions on its use.



Wear hearing protection.
Wear eye protection.
Wear breathing protection.



Conforms to relevant standards for electromagnetic compatibility.

Specifications

| | |
|----------------------|--|
| Engine Type: | 4 Stroke OHV |
| Running Wattage: | 3000W |
| Peak Wattage: | 3300W |
| Noise Level: | 55dBA |
| Rated Frequency: | 50HZ |
| Rated Voltage: | 230V |
| Amperage: | 13.04A |
| Outlets: | 2x 15A 230V AC 2x USB 1x 12V 8A DC |
| Net Weight: | 22kg |
| Fuel Type: | Unleaded gasoline |
| Fuel Tank Capacity: | 3.8L |
| Oil Type: | SAE 10W-30 |
| Engine Oil Capacity: | 0.45L |
| Start Type: | Recoil |
| L x W x H: | 475 x 280 x 430 mm |

SAFETY

SAFETY DEFINITIONS

The words DANGER, WARNING, CAUTION and NOTICE are used throughout this manual to highlight important information. Be certain that the meanings of these alerts are known to all who work on or near the equipment.



This safety alert symbol appears with most safety statements. It means attention, become alert, your safety is involved! Please read and abide by the message that follows the safety alerts symbol.

DANGER

Indicates a hazardous situation which, if not avoided, *will* result in death or serious injury.

WARNING

Indicates a hazardous situation which, if not avoided, *could* result in death or serious injury.

CAUTION

Indicates a hazardous situation which, if not avoided, *could* result in minor or moderate injury.

NOTICE

Indicates a situation which can cause damage to the generator, personal property and/or the environment, or cause the equipment to operate improperly.

WARNING

Connection of the product to a building's electrical system is not applicable.

NOTE: Indicates a procedure, practice or condition that should be followed in order for the generator to function in the manner intended.

SAFETY SYMBOL DEFINITIONS

| Symbol | Description |
|---|--|
|  | Safety Alert Symbol |
|  | Asphyxiation Hazard |
|  | Burn Hazard |
|  | Burst/Pressure Hazard |
|  | Don't leave tools in the area |
|  | Electrical Shock Hazard |
|  | Explosion Hazard |
|  | Fire Hazard |
|  | Lifting Hazard |
|  | Pinch-Point Hazard |
|  | Read Manufacturer's Instructions |
|  | Read Safety Messages Before Proceeding |
|  | Wear Personal Protective Equipment (PPE) |

SAFETY

GENERAL SAFETY RULES

DANGER



Never use the inverter in a location that is wet or damp. Never expose the inverter to rain, snow, water spray or standing water while in use. Protect the inverter from all hazardous weather conditions. Moisture or ice can cause a short circuit or other malfunction in the electrical circuit.



Never operate the inverter in an enclosed area. Engine exhaust contains carbon monoxide. Only operate the inverter outside and away from windows, doors and vents.

WARNING



Voltage produced by the inverter could result in death or serious injury.

- Never operate the inverter in rain or a flood plain unless proper precautions are taken to avoid being subject to rain or a flood.
- Never use worn or damaged extension cords.
- Always have a licensed electrician connect the inverter to the utility circuit.
- Never touch an operating inverter if the inverter is wet or if you have wet hands.
- Never operate the inverter in highly conductive areas such as around metal decking or steel works.
- Always use grounded extension cords. Always use three-wire or double-insulated power tools.
- Never touch live terminals or bare wires while the inverter is operating.
- Be sure the inverter is properly grounded before operating.

WARNING



Gasoline and gasoline vapors are extremely flammable and explosive under certain conditions.

- Always refuel the generator outdoors, in a well-ventilated area.
- Never remove the fuel cap with the engine running.
- Never refuel the inverter while the engine is running. Always turn engine off and allow the generator to cool before refueling.
- Only fill fuel tank with gasoline.
- Keep sparks, open flames or other form of ignition (such as match, cigarette, static electric source) away when refueling.
- Never overfill the fuel tank. Leave room for fuel to expand. Overfilling the fuel tank can result in a sudden overflow of gasoline and result in spilled gasoline coming in contact with HOT surfaces. Spilled fuel can ignite. If fuel is spilled on the inverter, wipe up any spills immediately. Dispose of rag properly. Allow area of spilled fuel to dry before operating the inverter.
- Wear eye protection while refueling.
- Never use gasoline as a cleaning agent.
- Store any containers containing gasoline in a well-ventilated area, away from any combustibles or source of ignition.
- Check for fuel leaks after refueling. Never operate the engine if a fuel leak is discovered.

WARNING



Never operate the inverter if powered items overheat, electrical output drops, there is sparking, flames or smoke coming from the inverter, or if the receptacles are damaged.



Never use the inverter to power medical support equipment.



Always remove any tools or other service equipment used during maintenance from the inverter before operating.

NOTICE

Never modify the inverter.

Never operate the inverter if it vibrates at high levels, if engine speed changes greatly or if the engine misfires often.

Always disconnect tools or appliances from the inverter before starting.

Symbol Usage

This manual contains important information that you need to know and understand in order to assure YOUR SAFETY and PROPER OPERATION OF EQUIPMENT. The following symbols help you recognize this information. Please read the manual and pay attention to these sections.

Save These Important Safety Instructions!

Read and understand all of these safety instructions. Be sure to retain them for future use.



WARNING!

Warnings indicate a certainty or strong possibility of personal injury or death if instructions are not followed.



CAUTION!

Cautions indicate a possibility of equipment damage if instructions are not followed properly.

NOTE:

Notes give helpful information.

Gasoline powered and electrical generating products can cause serious injury or death, or damage to other equipment or property, if the operator does not strictly observe all safety rules and take precautionary actions.

General Safety Precautions

Carbon Monoxide

- Carbon Monoxide is an odourless and colourless gas. Breathing exhaust fumes that contains this poisonous gas can cause unconsciousness and may lead to death.
- The engine exhaust from this product contains chemicals known to cause cancer, birth defects, or other reproductive harm.
- When this tool is running, ensure that the area is well ventilated. Never run the engine in an enclosed area. Run the engine in an open area or with an exhaust evacuation system in an enclosed area.
- NEVER use a generator inside homes, garages, crawlspaces, or other partially enclosed areas. Deadly levels of carbon monoxide can build up in these areas. Using a fan or opening windows and doors does NOT supply enough fresh air.
- ONLY use a generator outdoors and far away from open windows, doors, and vents. These openings can pull in generator exhaust.
- Even when you use a generator correctly, CO may leak into the home. ALWAYS use a battery-powered or battery-backup CO alarm in the home.
- If you start to feel sick, dizzy, or weak after the generator has been running, move to fresh air RIGHT AWAY. See a doctor. You could have carbon monoxide poisoning.



WARNING!

The exhaust contains poisonous carbon monoxide gas that can cause loss of consciousness and may lead to death.

Gasoline and Oil

This product requires oil and fuel. **THE ENGINE WILL NOT START WITHOUT OIL.** Work in well-ventilated area. Keep cigarettes, flames or sparks away from the work area or where gasoline is stored.

 **WARNING!** *Gasoline is extremely flammable and is explosive under certain conditions. Keep out of reach of children.*

- Gasoline fuel and fumes are flammable and potentially explosive. Use proper fuel storage and handling procedures. Always have multiple ABC class fire extinguishers nearby.
- Keep the generator and surrounding area clean at all times.
- Keep the generator at least 5 feet away from buildings and other equipment during operation.
- Fuel or oil spills must be cleaned up immediately. Dispose of fluids and cleaning materials as per any local, state, or federal codes and regulations. Store oily rags in a covered metal container.
- Never store fuel or other flammable materials near the generator.
- Do not smoke, or allow sparks, flames or other sources of ignition around the engine and fuel tank. Fuel vapours are explosive.
- Keep earthed conductive objects, such as tools, away from exposed, live electrical parts and connections to avoid sparking or arcing. These events could ignite fumes or vapours.
- Do not refill the fuel tank while the engine is running or while the engine is still hot. Do not operate the generator with known leaks in the fuel system.
- Excessive build-up of unburned fuel gases

in the exhaust system can create a potentially explosive condition. This build-up can occur after repeated failed start attempts, valve testing, or hot engine shutdown.

- Use only engine manufacturer recommended fuel and oil.

Hot Components

 **WARNING!** *Hot exhaust can burn you. Engine and exhaust system parts become very hot and remain hot for some time after the engine is run. Wear insulated gloves or wait until the engine and exhaust system have cooled down before handling these parts.*

Work Area

- Keep your work area clean and well lit. Cluttered benches and dark areas invite accidents.
- Do not operate power tools in explosive atmospheres, such as in the presence of flammable liquids, gases, or dust. Generators create sparks which may ignite the dust or fumes.
- Keep bystanders, children, and visitors away while operating a generator. Provide barriers or shields as needed.

Electrical Safety

- Keep all electrical equipment clean and dry. Replace any wiring where the insulation is cracked, cut eroded part or otherwise degraded. Replace terminals that are worn, discoloured, or corroded. Keep terminals clean and tight.
- Insulate all connections and disconnected wires.

- Do not abuse the power cord. Keep power cords away from heat, oil, sharp edges, or moving parts. Replace damaged power cords immediately. Damaged power cords increase the risk of electric shock.
- Do not operate the generator with wet hands. Do not expose generator to rain, snow or wet conditions. Water will increase the risk of electric shock. The generator is a potential source of electrical shock if not kept dry.
- Do not attempt to connect or disconnect load connections while standing in water, or on wet or soggy ground.
- Do not touch electrically energized parts of the generator and interconnecting cables or conductors with any part of the body, or with any non-insulated conductive object.
- Avoid body contact with earthed surfaces such as pipes, radiators, ranges, and refrigerators. There is an increased risk of electric shock if your body is earthed.
- When operating a power tool outside, use a premium quality outdoor extension cord. These extension cords are rated for outdoor use, and reduce the risk of electric shock.
- Earthed tools must be plugged into an outlet properly installed and earthed in accordance with all codes and ordinances. Never remove the earth prong or modify the plug in any way. Do not use any adapter plugs.
- Double insulated tools are equipped with a polarized plug where one blade is wider than the other. This plug fits in a polarized outlet only one way. If the plug does not fit fully in the outlet, reverse the plug. If it still does not fit, contact a qualified electrician to install a polarized outlet. Do not change the plug in any way. Double insulation eliminates the need for the three-wire earthed power cord and earthed power supply system.
- Before servicing equipment powered by the generator, disconnect the equipment from its power input.
- The generator must be earthed for fixed installations in accordance with all relevant electrical codes and standards before operation.
- Earthing provides a low-resistance path to carry electricity away from the user in the event of an electrical malfunction.
- All connections and conduits from the generator to the load must only be installed by trained and licensed electricians and in compliance with all relevant local, state, and federal electrical codes and standards, and other regulations where applicable.
- Connect the generator only to a load or electrical system (230 volt) that is compatible with the electrical characteristics and rated capacities of the generator.
- NEVER try to power building or home wiring by plugging the generator into a wall outlet, a practice known as "backfeeding." This is extremely dangerous and presents an electrocution risk to utility workers and neighbours served by the same utility transformer. It also bypasses some of the built-in household circuit protection devices.



Personal Safety



WARNING!

Do not sit, stand, or place objects on top of the generator regardless of whether it is running or not.

- Stay alert. Watch what you are doing, and use common sense when operating a generator. Do not use generator while tired or under the influence of drugs, alcohol, or medication. A moment of inattention while operating generators may result in serious personal injury.
 - Make note of the location of the engine power switch should you need to turn off the generator quickly.
 - Dress properly. Contain long hair, clothing, jewellery, and gloves as they can be caught in moving parts.
 - Avoid accidental starting. Make sure the power switch is in its "OFF" position, and disconnect the spark plug wire when not in use.
 - Remove adjusting keys or wrenches before turning the generator on. A wrench or a key that is left attached to a rotating part of the generator may result in personal injury.
 - Do not overreach. Keep proper footing and balance at all times.
 - Use safety equipment. Always wear eye protection. Wear AS/NZS approved safety impact eye goggles. Dust mask, non-skid safety shoes, safety gloves, hard hat, or hearing protection must be used for appropriate conditions.
 - Do not use the generator if the power switch does not turn it on or off. Any generator that cannot be controlled with the power switch is dangerous and must be repaired.
- Do not force the generator. Use the correct generator for your application. The correct generator will do the job better and safer at the rate for which it is designed.

Generator Use and Care

- Make sure the power switch is in its "OFF" position and disconnect the spark plug wire before making any adjustment, changing accessories, or storing the generator. Such preventive safety measures reduce the risk of starting the generator accidentally.
- Store idle generators out of reach of children and other untrained persons. Generators are dangerous in the hands of untrained users.
- Maintain generators with care. Do not use a damaged generator.
- Tag damaged generators "Do not use" until repaired.
- Check for misalignment or binding of moving parts, breakage of parts, and any other condition that may affect the generator's operation. If damaged, have the generator serviced before using. Many accidents are caused by poorly maintained generators.
- Use only accessories that are recommended by the manufacturer for your model. Accessories that may be suitable for one generator may become hazardous when used on another generator.

Servicing

- Maintain labels and name plates on the generator and engine. These carry important information. If unreadable or missing, contact your Powertec agent immediately for a replacement.

- Generator service must be performed only by qualified repair personnel. Service or maintenance performed by unqualified personnel could result in a risk of injury.
- When servicing a generator, use only genuine replacement parts. Follow all appropriate instructions in this manual. Use of unauthorized parts or failure to follow maintenance instructions may create a risk of electric shock or injury.

 **WARNING!**

People with pacemakers should consult their physician(s) before using this product. Electromagnetic fields in close proximity to a heart pacemaker could cause interference to or failure of the pacemaker.

Installation

- Ensure installation meets all applicable safety, and local and national electrical codes. Have installation performed by a qualified, licensed electrician and building contractor.
- All electrical work, including the earth connection, should be completed by a licensed electrician.
- Any separate fuel storage or generator supply facility must be built or installed in full compliance with all relevant local, state, and federal regulations.
- It is recommended to use the generator only in well ventilated outdoor areas. A running gasoline engine will generate carbon monoxide, a colourless, odourless gas that, if inhaled, can cause serious injury or death. If the generator is installed indoors, exhaust fumes must be piped out of the building using leak-free, heat resistant piping. Pipes and silencer should not use any flammable materials, nor should they be installed near the same. Generator exhaust fumes must be within legal limits and installation must always meet local building codes.

- If the generator is installed outdoors, it must be weatherproofed and should be soundproofed. It should not be run outdoors without protection of the generator and wiring conduit.
- The supporting floor/ground surface should be level, and strong enough to safely hold the weight of the generator.

Mechanical

- Always make sure the power switch is in its "OFF" position.
- Before carrying out maintenance, disconnect the spark plug wire, and allow the engine to completely cool.
- Check for damaged parts. Before using the generator, any part that appears damaged should be carefully checked to determine that it will operate properly and perform its intended function. Check for alignment and binding of moving parts, any broken parts or mounting fixtures, and any other condition that may affect proper operation technician.
- The generator is designed with guards for protection from moving parts. In any case, care must still be taken to protect personnel and equipment from other mechanical hazards when working around the generator.
- Do not operate the generator with safety guards removed. While the generator is running, do not attempt to reach around the safety guard for maintenance or any other reason.
- Keep hands, arms, long hair, loose clothing, and jewellery away from moving parts.

Be aware that when engine parts are moving fast they cannot be seen clearly.

- Keep access doors on enclosures closed and locked when access is not required.
- When working on or around the generator always wear protective clothing including AS/NZS approved safety gloves, safety eye goggles, and safety hat.
- Do not alter or adjust any part of the generator that is assembled and supplied by the manufacturer.
- Always follow and complete scheduled engine and generator maintenance.

Chemicals

- Avoid contact with hot fuel, oil, exhaust fumes, and hot solid surfaces.
- Avoid body contact with fuels, oils and lubricants used in the generator. If swallowed, seek medical treatment immediately. Do not induce vomiting if fuel is swallowed. For skin contact, immediately wash with soap and water. For eye contact, immediately flush eyes with clean water and seek medical attention.

Noise

Prolonged exposure to noise levels above 85dBA is hazardous to hearing. Always wear AS/NZS approved ear protection when operating or working around the Generator when it is running.

Extension Cords

If an extension cord (not included) is used, make sure to use only AS/NZS approved cords having the correct gauge and length according to the following table:

| Output Load (W) | Cord Lengths | |
|-----------------|--------------------|--------------------|
| | 15m | 15-30m |
| 0-700 | 1.5mm ² | 2.5mm ² |
| 700-1000 | 1.5mm ² | 2.5mm ² |
| 1000-1300 | 2.5mm ² | 2.5mm ² |
| 1300-1600 | 2.5mm ² | 2.5mm ² |
| 1600-1800 | 2.5mm ² | 2.5mm ² |

FEATURES



① **Fuel Cap and Vent:** Open the vent to run the engine and close the vent when the engine is off.

② **Control Panel:** Contains the reset breaker, outlets and warning lights.

③ **Spark Plug Access Cover:** Remove the cover to service the spark plug.

④ **Recoil Handle:** Pull to start the engine.

⑤ **Engine Control Switch:** Sets the choke, turns the fuel on and off.

⑥ **Engine Service Panel:** Remove the panel to access the engine for maintenance.

⑦ **Muffler and Spark Arrestor:** Avoid contact until the engine is cooled down. The spark arrestor prevents sparks from exiting the muffler. It must be removed for servicing.

⑧ **Engine Cooling Vents:** Helps move airflow in unit to regulate engine temperatures.

⑨ **Recoil Handle Protective Cover:** Prevents pull cord wire from damaging inverter body.

FEATURES

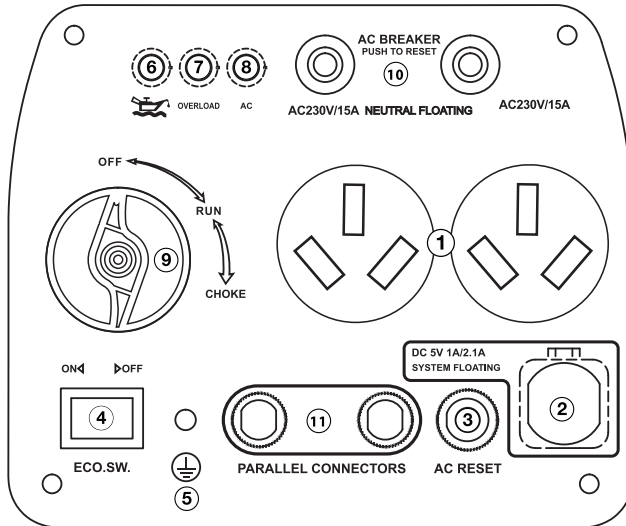

CONTROL PANEL FEATURES

- 1 230 Volt, 15A Duplex Outlet:** This outlet is capable of carrying a maximum of 15A
- 2 USB Duplex:** 5V DC that come in 1 amps and 2.1 amps.
- 3 Reset Breaker:** If the inverter is overloaded, the reset breaker will trip. The engine will continue to run, but there will be no output from the inverter. Unplug the devices and reduce the load. Push in the reset breaker to reset it.
- 4 Efficiency Mode Switch:** When turned to the ON position, the engine will sense the load needed and run at a slower RPM to save fuel.
- 5 Ground Terminal:** The ground terminal is used to externally ground the inverter.
- 6 Low Oil LED:** Indicates low oil level.
- 7 Overload LED:** Indicates that the inverter is overloaded.
- 8 Output Ready LED:** Indicates the inverter is ready to be used.
- 9 Engine Control Switch:** Turn position to CHOKE to start the engine, and turn to RUN position once the engine is running. Switch to OFF to stop inverter.
- 10 AC Breaker:** If the inverter is overloaded, the reset breaker will trip to block current.
- 11 Parallel Connectors:** To increase AC power output, the connector sockets are used to connect the two same type generator with special paralleling cords. The connector sockets is only used to the communication between the inverters, they can not used for AC power output. The special paralleling cords shall be purchase separately, and they shall be approved by certification body.

OPERATION

BEFORE STARTING THE INVERTER



**BEFORE STARTING THE INVERTER,
REVIEW SAFETY SECTION**

Location Selection – Before starting the inverter, avoid exhaust and location hazards by verifying:

- You have selected a location to operate the inverter that is outdoors and well ventilated.
- You have selected a location with a level and solid surface on which to place the inverter.
- You have selected a location that is at least 6 feet (1.8 m) away from any building, other equipment or combustible material.
- If the inverter is located close to a building, make sure it is not located near any windows, doors and/or vents.

| ⚠ DANGER | |
|--|---|
| <p>Using a generator indoors CAN KILL YOU IN MINUTES. Generator exhaust contains carbon monoxide. This is a poison you cannot see or smell.</p> | |
| <p>NEVER use inside a home or garage, EVEN IF doors and windows are open.</p> | <p>Only use OUTSIDE and far away from windows, doors, and vents.</p> |
| <p>Avoid other generator hazards. READ MANUAL BEFORE USE.</p> | |

| ⚠ WARNING | |
|------------------|---|
| | <p>Always operate the inverter on a level surface. Placing the inverter on non level surfaces can cause the inverter to tip over, causing fuel and oil to spill. Spilled fuel can ignite if it comes in contact with an ignition source such as a very hot surface.</p> |

| NOTICE | |
|--|--|
| <p>Only operate the inverter on a solid, level surface. Operating the inverter on a surface with loose material such as sand or grass clippings can cause debris to be ingested by the inverter that could:</p> <ul style="list-style-type: none"> • Block cooling vents • Block air intake system | |

Weather – Never operate your inverter outdoors during rain, snow or any combination of weather conditions that could lead to moisture collecting on, in or around the generator.

Dry Surface – Always operate the inverter on a dry surface free of any moisture.

No Connected Loads – Make sure the inverter has no connected loads before starting it. To ensure there are no connected loads, unplug any electrical extension cords that are plugged into the control panel receptacles.

| NOTICE |
|--|
| <p>Starting the inverter with loads already applied to it could result in damage to any appliance being powered off the inverter during the brief start-up period.</p> |

Grounding the Inverters

Consult with your local municipalities for your grounding codes.

| ⚠ WARNING | |
|------------------|---|
| | <p>Be sure the inverter is properly connected to earth ground before operating.</p> |

OPERATION

POWERCORD

Using Extension Cords

Powertec assumes no responsibility for the content within this table. The use of this table is the responsibility of the user only. This table is intended for reference only. The results produced by using this table are not guaranteed to be correct or applicable in all situations as the type and construction of cords are highly variable. Always check with local regulations and a licensed electrician prior to installing or connecting an electrical appliance

Extension Cord Wire Gauge Size

| AMPS | LENGTH OF EXTENSION CORD (ft) | | | | | | | | |
|------|-------------------------------|----|----|----|----|----|----|-----|-----|
| | 10 | 20 | 30 | 40 | 50 | 60 | 80 | 100 | 120 |
| 5 | 20 | 18 | 16 | 14 | 12 | 12 | 10 | 10 | 8 |
| 10 | 18 | 16 | 14 | 12 | 12 | 10 | 10 | 8 | 8 |
| 15 | 16 | 14 | 12 | 12 | 10 | 10 | 8 | 8 | 6 |
| 20 | 14 | 12 | 12 | 10 | 10 | 8 | 8 | 6 | 6 |
| 25 | 12 | 12 | 10 | 10 | 8 | 8 | 6 | 6 | 6 |
| 30 | 12 | 10 | 10 | 8 | 8 | 6 | 6 | 6 | 6 |
| 35 | 10 | 10 | 8 | 8 | 6 | 6 | 6 | 6 | 6 |

INVERTER PARALLELING OPERATION

 **DANGER**



Never connect the paralleling cord to the inverters with the inverters running. The inverters must not be running and both the paralleling cord switches must be off when connecting the cords.

 **WARNING**



Do not attempt to parallel the **Powertec** inverter with any other manufacturers' inverters. Do not use the paralleling cord for any application other than inverter paralleling. Do not use this cord on other manufacturers' inverters.



Always ensure that both ends of the paralleling cord are switched off before connecting the inverters.

INVERTER PARALLELING OPERATION

- Using only the Powertec paralleling cord with both cord switches set to **OFF** (O), connect one male plug to one inverter and connect the remaining plug into the other inverter. Either of the receptacles on the inverters can be used.
- Start one of the inverters and wait until the output ready light is on.
- Turn both cord switches to ON (I).
- Start the remaining inverter; wait until the output ready light is on before connecting the load.
- When power is present, a light will illuminate in the three-prong plug that is plugged into the inverter.
- To stop the inverters, unplug all connected loads, turn both cord switches to **OFF** (O) and unplug the cord on each inverter.
- If during operation the inverters' output is stopped due to overloading, reduce the connected load by unplugging appliances, and then push the reset button and restart the inverter. When the ready light is on, the load can be reconnected.

OPERATION

INITIAL OIL FILL



**BEFORE ADDING ENGINE OIL, REVIEW
SAFETY SECTION**

NOTICE

Engine oil must be added when the inverter is on a flat, level surface, or an inaccurate reading may result. Do not overfill. If the engine is overfilled with oil, it can cause serious engine damage.

1. Loosen the screw and remove the engine oil fill/drain plug service panel to access the oil fill/drain plug (see Figure 1)

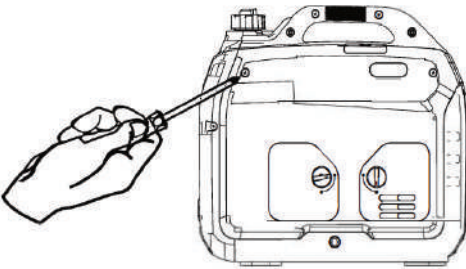

Figure 1: Engine Service Panel

2. Clean the area around the oil fill/drain plug and remove plug (See Figure 2).

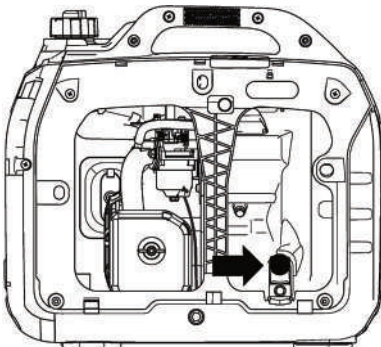

Figure 2: Oil Fill/Drain Plug

3. Using the supplied funnel pour the oil into the engine (see Figure 3).

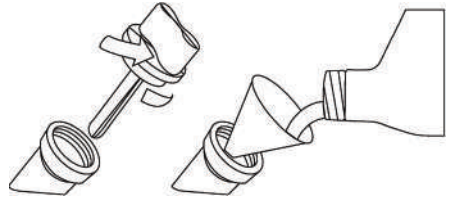

Figure 3: Oil Funnel

4. Do not overfill, if oil level is too high, oil will drain out through the fill plug. See correct oil level in Figure 4.

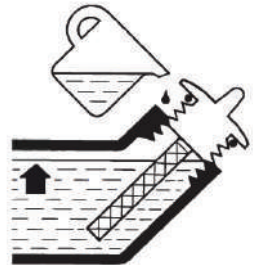

Figure 4: Engine Oil Correct Level

OPERATION

ADDING/CHECKING ENGINE FLUIDS AND FUEL



BEFORE ADDING/CHECKING ENGINE FLUIDS AND FUEL, REVIEW SAFETY SECTION

DANGER



Filling the fuel tank with gasoline while the inverter is running can cause gasoline to leak and come in contact with hot surfaces that can ignite the gasoline.

Before starting the inverter, always check the level of:

- Engine oil
- Gasoline in the fuel tank

Once the inverter is started and the engine gets warm, it is not safe to add gasoline to the fuel tank or engine oil to the engine while the engine is running or the engine and muffler are hot.

CHECKING AND/ OR ADDING ENGINE OIL

WARNING



Internal pressure can build in the engine crankcase while the engine is running. Removing the oil fill plug/dipstick while the engine is hot can cause extremely hot oil to spray out of the crankcase and can severely burn skin. Allow engine oil to cool for several minutes before removing the oil fill plug/dipstick.

The unit as shipped does not contain oil in the engine. You must add engine oil before starting the inverter for the first time. See *Initial Oil Fill* for instructions on checking engine oil level and the procedure for adding engine oil.

NOTICE

The engine does not contain engine oil as shipped. Attempting to start the engine without adding engine oil will permanently damage internal engine components.

The engine is equipped with a low oil shutdown switch. If the oil level becomes low, the engine may shut down and not start until the oil is filled to the proper level.

The owner of the inverter is responsible to ensure the proper oil level is maintained during the operation of the generator. Failure to maintain the proper oil level can result in engine damage.

ADDING GASOLINE TO THE FUEL TANK

WARNING



Never refuel the inverter while the engine is running.



Always turn the engine off and allow the inverter to cool before refueling.

CAUTION



Avoid prolonged skin contact with gasoline. Avoid prolonged breathing of gasoline vapors.

Required Gasoline - Only use gasoline that meets the following requirements:

- Unleaded gasoline only
- Gasoline with maximum 10% ethanol added
- Gasoline with an 87 octane rating or higher

Filling the Fuel Tank - Follow the steps below to fill the fuel tank:

1. Shut off the inverter.
2. Allow the inverter to cool down so all surface areas of the muffler and engine are cool to the touch.
3. Move the inverter to a flat surface.
4. Clean area around the fuel cap.
5. Remove the fuel cap by rotating counterclockwise.

NOTICE

Do not overfill the fuel tank. Spilled fuel will damage some plastic parts.

6. Slowly add gasoline into the fuel tank. Be very careful not to overfill the tank. The gasoline level should NOT be higher than the red ring (see Figure 5).
7. Install the fuel cap by rotating clockwise.

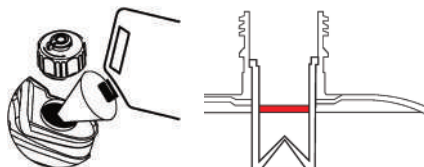

Figure 5: Maximum Gasoline Fill Level

OPERATION

STARTING THE INVERTER



**BEFORE STARTING THE INVERTER,
REVIEW SAFETY SECTION**

For proper starting and operation of the inverter, make sure you review the inverter features and their descriptions

Before attempting to start the inverter, verify the following:

- The engine is filled with engine oil (see Figure 4: *Engine Oil Correct Level*)
- The inverter is situated in a proper location (see *Location Selection*)
- The inverter is on a dry surface (see *Weather and Dry Surface*)
- All loads are disconnected from the inverter (see *No Connected Loads*)
- The inverter is properly grounded (see *Grounding the Inverter*)

| ⚠ DANGER | |
|-----------------|--|
| | Never use the inverter in a location that is wet or damp. Never expose the inverter to rain, snow, water spray or standing water while in use. Protect the inverter from all hazardous weather conditions. Moisture or ice can cause a short circuit or other malfunction in the electrical circuit. |
| | Never operate the inverter in an enclosed area. Engine exhaust contains carbon monoxide. Only operate the inverter outside and away from windows, doors and vents. |

Starting PT3200i

1. Check oil levels. If it is the first time starting make sure to add oil (see *Initial Oil Fill*)
2. Turn the fuel tank vent to the **ON** position (see Figure 6).

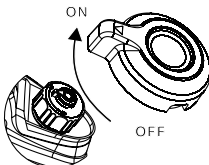

Figure 6: fuel tank vent -

3. Turn the engine/fuel control switch to the **CHOKE** position (see Figure 7).

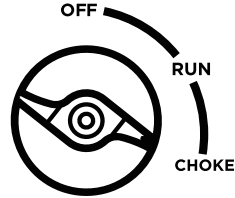

Figure 7: Turn Engine/Fuel Switch to CHOKE Position

4. Firmly grasp and pull the recoil handle slowly until you feel increased resistance. At this point, apply a rapid pull while pulling out from the inverter (see Figure 8).

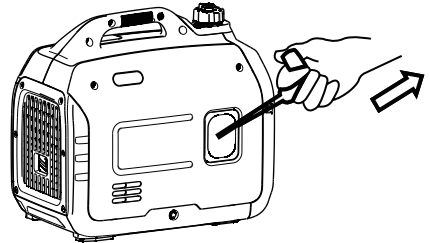

Figure 8: Pull the Recoil Handle out from Inverter

5. As the engine starts and stabilizes, turn the choke switch back in to the **RUN** position (see Figure 9).

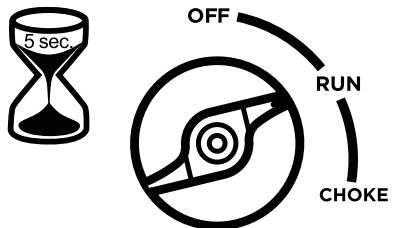

Figure 9: Turn Engine/Fuel Switch to RUN

OPERATION

STOPPING THE INVERTER

Normal Operation

During normal operation, use the following steps to stop your inverter:

1. Remove any connected loads from the control panel receptacles.
2. Allow the inverter to run at "no load" to reduce and stabilize engine and alternator temperatures.
3. Move the engine control switch to the **OFF** position (see Figure 10) .

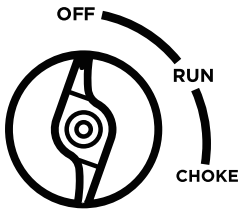

Figure 10: Turn Engine/Fuel Switch to OFF Position

4. Turn the fuel tank vent to the **OFF** position

During an Emergency

If there is an emergency and the inverter must be stopped quickly, move the engine control switch to the **OFF** position immediately (see Figure 10).

USING EFFICIENCY MODE

The inverter is equipped with an efficiency mode switch to minimize fuel consumption. In efficiency mode, the inverter will sense the load and adjust the engine RPM to the current load requirements. Efficiency mode should be used only after the inverter has been warmed up to operating temperature.

1. To turn on the efficiency mode, press the switch to the ON position).
2. If no load is present, the inverter RPM will drop down to an idle speed.
3. As a load is applied, the inverter will sense the load and engine RPM will increase according to the load applied.
4. To run the inverter at maximum power and RPM, press the efficiency mode switch to the OFF position.

RESETTING THE RESET BREAKER

The inverter will trip the breaker and automatically disconnect from the load when the controls sense a predetermined overload condition. The inverter engine will continue to run, but there will not be any electrical output.

1. Turn off all devices and unplug them from the inverter.
2. Determine the wattage required from the devices being powered by the inverter. Make sure the wattage required does not exceed the maximum output of the inverter.
3. Press in the reset breaker to reset it (see Figure 11).

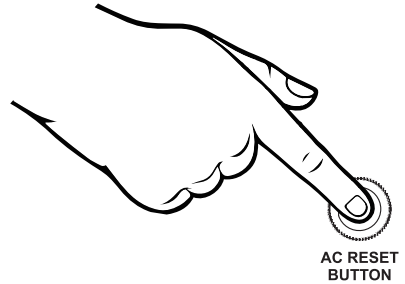

Figure 11: Press in reset breaker

4. Plug the devices in to the inverter.
5. Turn on the devices as needed.

MAINTENANCE



BEFORE PERFORMING MAINTENANCE ON THE INVERTER, REVIEW THE SAFETY SECTION, AS WELL AS THE FOLLOWING SAFETY MESSAGES.

| ⚠ WARNING | |
|------------------|--|
| | Avoid accidentally starting the inverter during maintenance by removing the spark plug boot from the spark plug. For electric start inverters, also disconnect the battery cables from the battery (disconnect the black negative (-) cable first) and place the cables away from the battery posts to avoid arcing. |
| | Allow hot components to cool to the touch prior to performing any maintenance procedure. |
| | Internal pressure can build in the engine crankcase while the engine is running. Removing the oil fill plug/ dipstick while the engine is hot can cause extremely hot oil to spray out of the crankcase and can severely burn skin. Allow engine oil to cool for several minutes before removing the oil fill plug/dipstick. |
| | Always perform maintenance in a well ventilated area. Gasoline fuel and fuel vapors are extremely flammable and can ignite under certain conditions. |

| ⚠ CAUTION | |
|------------------|--|
| | Avoid skin contact with engine oil or gasoline. Prolonged skin contact with engine oil or gasoline can be harmful. Frequent and prolonged contact with engine oil may cause skin cancer. Take protective measures and wear protective clothing and equipment. Wash all exposed skin with soap and water. |

| ⚠ WARNING | |
|------------------|--|
| | Failure to perform periodic maintenance or not following maintenance procedures can cause the inverter to malfunction and could result in death or serious injury. |

| NOTICE | |
|---|--|
| Periodic maintenance intervals vary depending on inverter operating conditions. Operating the inverter under severe conditions, such as sustained high load, high-temperature, or unusually wet or dusty environments, will require more frequent periodic maintenance. The intervals listed in the maintenance schedule should be treated only as a general guideline. | |

Following the maintenance schedule is important to keep the inverter in good operating condition. The following is a summary of maintenance items by periodic maintenance intervals.

TABLE 1: MAINTENANCE SCHEDULE - OWNER PERFORMED

| Maintenance Item | Before Every Use | After First 20 Hours or First Month of Use | After 50 Hours of Use or Every 6 Months | After 100 Hour of Use or Every 6 Months | After 300 Hours of Use or Every Year |
|-------------------------|------------------|--|---|---|--------------------------------------|
| Engine Oil | Check Level | Change | Change | - | - |
| Cooling Features | Check/Clean | - | - | - | - |
| Air Filter | Check | - | Clean* | - | Replace |
| Spark Plug | - | - | - | Check/Clean | Replace |
| Spark Arrestor | - | - | - | Check/Clean | - |

*Service more frequently if operating in dry and dusty conditions

MAINTENANCE

ENGINE OIL MAINTENANCE

Engine Oil Specification

1. Only use the engine oil specified in Figure 12.
2. Only use 4-stroke/cycle engine oil. **NEVER USE 2-STROKE/CYCLE OIL.** Synthetic oil is an acceptable substitute for conventional oil.

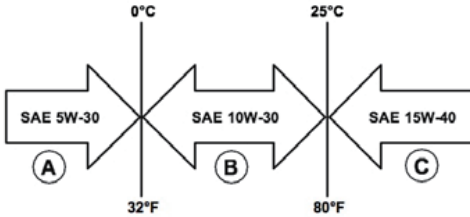

Figure 12: Recommended Oil

CHECKING ENGINE OIL

NOTICE

Always maintain proper engine oil level. Failure to maintain proper engine oil level could result in severe damage to the engine and/or shorten the life of the engine.

Always use the specified engine oil. Failure to use the specified engine oil can cause accelerated wear and/or shorten the life of the engine.

Engine oil level should be checked before every use.

1. Always operate or maintain the inverter on a flat surface.
2. Stop engine if running.
3. Let engine sit and cool for several minutes (allow crankcase pressure to equalize).
4. Remove the engine service panel to access the oil fill/drain plug.
5. With a damp rag, clean around the oil fill/drain plug.
6. Remove the oil fill/drain plug.
7. Check oil level: When checking the engine oil, remove the oil fill/ drain plug.
 - The oil level is acceptable if oil is visible at the bottom of the threads of the oil fill plug.
 - If oil level is low, add to the correct level using the supplied oil fill bottle. Do not overfill the oil crankcase.

NOTICE

Engine oil must always be checked and added when the inverter is on a flat, level surface, or an inaccurate reading may result, causing serious engine damage.

ADDING ENGINE OIL

1. Always operate or maintain the inverter on a flat surface.
2. Stop engine if running.
3. Let engine sit and cool for several minutes (allow crankcase pressure to equalize).
4. Remove the engine service panel to gain access to the oil fill/drain plug.
5. Thoroughly clean around the oil fill/drain plug.
6. Remove the oil fill/drain plug.
7. Select the proper engine oil as specified in Figure 12.
8. Using the supplied oil funnel, slowly add engine oil to the engine. Stop frequently to check the oil level and avoid overfilling.

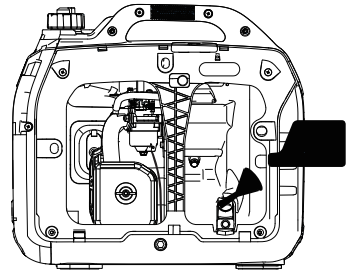

9. Continue to add oil until the oil is at the correct level.

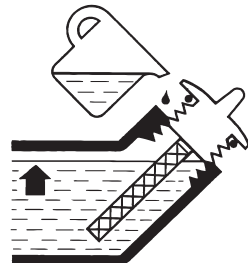

MAINTENANCE

CHANGING ENGINE OIL

1. Stop the engine.
2. Let engine sit and cool for several minutes (allow crankcase pressure to equalize).
3. Remove the engine service panel to gain access to the oil fill/drain plug.
4. Place oil pan (or suitable container) under the oil fill/drain plug (see Figure 13).

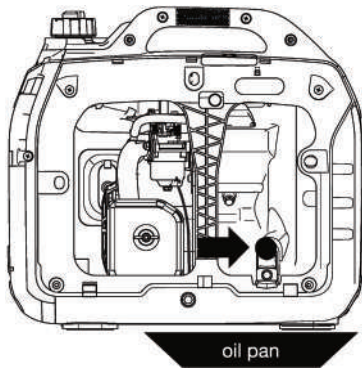

Figure 13: Place oil pan under oil fill/drain plug

5. With a damp rag, thoroughly clean around the oil fill/drain plug.
6. Tilt the inverter so the oil drains down the through into the container.



Figure 14: Carefully tip inverter so oil flows into oil pan

7. Allow oil to completely drain.
8. Fill crankcase with oil following the steps outlined in *Adding Engine Oil*.
9. Dispose of used engine oil properly.

NOTICE

Never dispose of used engine oil by dumping the oil into a sewer, on the ground, or into groundwater or waterways. Always be environmentally responsible. Follow the guidelines of the EPA or other governmental agencies for proper disposal of hazardous materials. Consult local authorities or reclamation facility.

AIRFILTER MAINTENANCE

⚠ WARNING



Never use gasoline or other flammable solvents to clean the air filter. Use only household detergent soap to clean the air filter.

Cleaning the Air Filter

The air filter must be cleaned after every 50 hours of use or 3 months (frequency should be increased if inverter is operated in a dusty environment).

1. Turn off the inverter and let it cool for several minutes if running.
2. Remove the engine service panel to gain access to the air filter.
3. Unscrew the air cleaner cover and tip the cover down (see Figure 15)
4. Remove the foam element from the air cleaner housing.

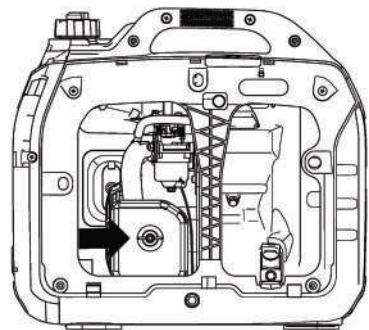

Figure 15: Unscrew air cleaner cover

MAINTENANCE

- Wash the foam air filter element by submerging the element in a solution of household detergent soap and warm water. Slowly squeeze the foam to thoroughly clean.

NOTICE

NEVER twist or tear the foam air filter element during cleaning or drying. Only apply slow but firm squeezing action.

- Rinse in clean water by submerging the air filter element in fresh water and applying a slow squeezing action (see Figure 16).



Figure 16

NOTICE

Never dispose of soap cleaning solution used to clean the air filter by dumping the solution into a sewer, on the ground, or into ground water or waterways. Always be environmentally responsible. Follow the guidelines of the EPA or other governmental agencies for proper disposal of hazardous materials. Consult local authorities or reclamation facility.

- Dispose of used soap cleaning solution properly.
- Dry the air filter element by again applying a slow firm squeezing action.
- Return the air filter element to its position in the air cleaner housing.
- Install the air cleaner cover, making sure the tabs lock into place.
- Install the engine service panel.

DRAINING THE FLOAT BOWL

- Remove the engine service panel to access the carburetor.
- Locate the clear plastic hose from the float that is exiting out the bottom of the inverter, and place a suitable container under it to catch the drained fuel (see Figure 17).

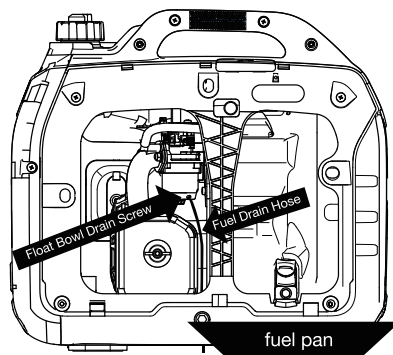

Figure 17: Fuel drain hose

- Loosen the float bowl drain screw (see Figure 18) until fuel is seen draining from the float bowl.

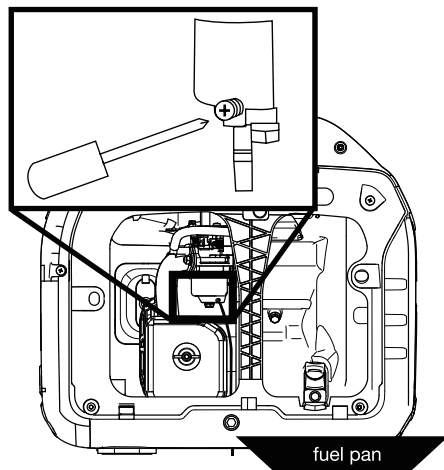

Figure 18: Loosen float bowl screw

- Allow fuel to drain into the container, and then tighten the float bowl drain screw.

NOTICE

Never dispose of fuel by dumping fuel into a sewer, on the ground, or into groundwater or waterways. Always be environmentally responsible. Follow the guidelines of the EPA or other governmental agencies for proper disposal of hazardous materials. Consult local authorities or reclamation facility.

- Install the engine service panel.

MAINTENANCE

SPARK PLUG MAINTENANCE

The spark plug must be checked and cleaned after every 100 hours of use or 6 months and must be replaced after 300 hours of use or every year.

1. Stop the inverter and let it cool for several minutes if running.
2. Move the inverter to a flat, level surface.
3. Slide the spark plug access cover off the housing (see Figure 19).

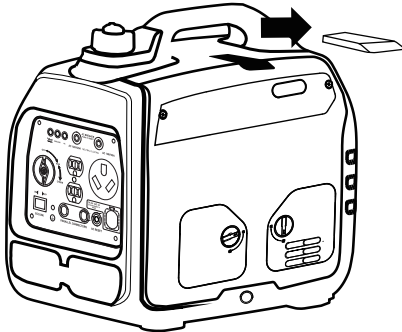

Figure 19: Slide off spark plug cover

4. Remove the spark plug boot by firmly pulling the plastic spark plug boot handle directly away from the engine.

NOTICE

Never apply any side load or move the spark plug laterally when removing the spark plug. Applying a side load or moving the spark plug laterally may crack and damage the spark plug boot.

5. Clean area around the spark plug.
6. Using the spark plug socket wrench provided, remove the spark plug from the cylinder head (see Figure 20).

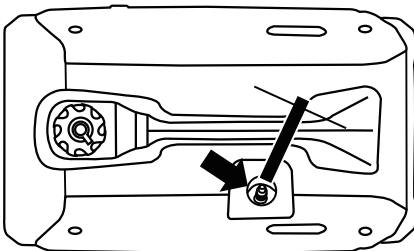
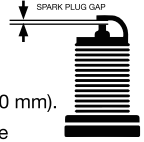

Figure 20: Remove spark plug with socket wrench

7. Place a clean rag over the opening created by the removal of the spark plug to make sure no dirt can get into the combustion chamber.

8. Inspect the spark plug for:

- Cracked or chipped insulator
- Excessive wear
- Spark plug gap of 0.032 in. (0.80 mm).



If the spark plug fails any one of the conditions listed above, replace the plug.

NOTICE

Only use the recommended spark plug. See chart below. Using a non-recommended spark plug could result in damage to the engine.

9. Install the spark plug by carefully following the steps outlined below:
 - a. Carefully insert the spark plug back into the cylinder head. Hand-thread the spark plug until it bottoms out.
 - b. Using the spark plug socket wrench provided, turn the spark plug to ensure it is fully seated.
 - c. Replace the spark plug boot, making sure the boot fully engages the spark plug's tip.
 - d. Install the spark plug access cover.

MAINTENANCE

CLEANING THE SPARK ARRESTOR

Check and clean the spark arrestor after every 100 hours of use or 6 months.

1. Stop the inverter and let it cool for several minutes if running.
2. Move the inverter to a flat, level surface.
3. Remove the screws holding the muffler cover in place (see Figure 21).

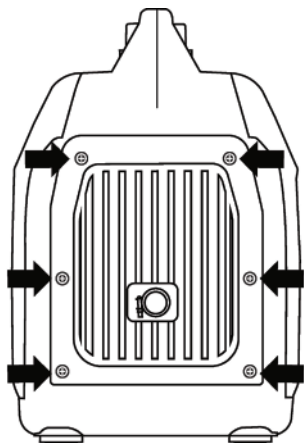

Figure 21: Remove screws holding muffler cover

4. Loosen the clamp holding the spark arrestor onto the muffler.
5. Slide the spark arrestor band clamp off the spark arrestor screen.
6. Pull the spark arrestor screen off the muffler exhaust pipe.
7. Using a wire brush, remove any dirt and debris that may have collected on the spark arrestor screen.
8. If the spark arrestor screen shows signs of wear (rips, tears or large openings in the screen), replace the spark arrestor screen.
9. Install the spark arrestor components in the following order:
 - a. Place spark arrestor screen over the muffler exhaust pipe. Push on the screen until it fully bottoms out.
 - b. Place the spark arrestor band clamp over the screen and tighten with a flathead screwdriver
10. Replace the discharge gate.

CLEANING THE INVERTER

It is important to inspect and clean the inverter before every use.

Clean All Engine Air Inlet and Outlet Ports - Make sure all engine air inlet and outlet ports are clean of any dirt and debris to ensure the engine does not run hot.

STORAGE

WARNING



Never store an inverter with fuel in the tank indoors or in a poorly ventilated area where the fumes can come in contact with an ignition source such as a: 1) pilot light of a stove, water heater, clothes dryer or any other gas appliance; or 2) spark from an electric appliance.

NOTICE

Gasoline stored for as little as 60 days can go bad, causing gum, varnish and corrosive buildup in fuel lines, fuel passages and the engine. This corrosive buildup restricts the flow of fuel, preventing an engine from starting after a prolonged storage period.

Proper care should be taken to prepare the inverter for any storage

1. Clean the inverter as outlined in *Cleaning the Inverter*.
2. Siphon all gasoline from the fuel tank as best as possible.
3. Start the engine and allow the inverter to run until all the remaining gasoline in the fuel lines and carburetor is consumed and the engine shuts off.
4. Drain any remaining fuel from the float bowl. See *Draining the Float Bowl*.
5. Change the oil (see *Changing Engine Oil*).
6. Remove the spark plug (see *Spark Plug Maintenance*) and place about 1 tablespoon of oil in the spark plug opening. While placing a clean rag over the spark plug opening, slowly pull the recoil handle to allow the engine to turn over several times. This will distribute the oil and protect the cylinder wall from corroding during storage.
7. Replace the spark plug (see *Spark Plug Maintenance*).
8. Move the inverter to a clean, dry place for storage.

TROUBLESHOOTING

⚠ WARNING



Before attempting to service or troubleshoot the generator, the owner or service technician must first read the owner's manual and understand and follow all safety instructions. Failure to follow all instructions may result in conditions that can lead to voiding of the EPA certification or product warranty, serious personal injury, property damage or even death.

| PROBLEM | POTENTIAL CAUSE | SOLUTION |
|--|---|--|
| Engine is running, but no electrical output. | 1. Reset breaker is tripped. | 1. Reset the reset breaker (see page 16). |
| | 2. The power cord's plug connector is not fully engaged in the inverter's outlet. | 2. Verify plug connector is firmly engaged in the inverter's outlet. |
| | 3. Faulty or defective power cord | 3. Replace power cord. |
| | 4. Faulty or defective electrical appliance | 4. Try connecting a known good appliance to verify the inverter is producing electrical power. |
| Engine will not start or remain running while trying to start. | 1. Inverter is out of gasoline. | 1. Add gasoline to the inverter (see page 14). |
| | 2. Fuel flow is obstructed. | 2. Inspect and clean fuel delivery passages. |
| | 3. Dirty air filter | 3. Check and clean the air filter (see page 19). |
| | 4. Low oil level shutdown switch is preventing the unit from starting. | 4. Check oil level and add oil if necessary (see page 18). |
| | 5. Spark plug boot is not fully engaged with the spark plug tip. | 5. Firmly push down on the spark plug boot to ensure the boot is fully engaged. |
| | 6. Spark plug is faulty. | 6. Remove and check the spark plug. Replace if faulty (see pages 21). |
| | 7. Dirty/plugged spark arrestor | 7. Check and clean the spark arrestor (see page 22). |
| | 8. Stale fuel | 8. Drain fuel and replace with fresh fuel. |
| Inverter suddenly stops running. | 1. Inverter is out of fuel. | 1. Check fuel level (see page 14). Add fuel if necessary. |
| | 2. The low oil shut down switch has stopped the engine. | 2. Check oil level and add oil if necessary (see page 18). |
| | 3. Too much load | 3. Restart the inverter and reduce the load. |
| Engine runs erratic; does not hold a steady RPM. | 1. Choke was left in the CHOKE position. | 1. Move choke to the RUN position |
| | 2. Dirty air filter | 2. Clean the air filter (see page 19). |
| | 3. Applied loads maybe cycling on and off | 3. As applied loads cycle, changes in engine speed may occur; this is a normal condition. |

Wattage Reference Guide

| Appliances | Approx Run (W) | Approx Start (W) | Appliances | Approx Run (W) | Approx Start (W) |
|-----------------------------|----------------|------------------|------------------------------|----------------|------------------|
| Microwave 750W | 750 | 1200 | Central Air Conditioner: | | |
| Coffee Maker | 1750 | 1750 | 10,000 BTU | 1500 | 2200 |
| Electric Clothes Drier | 5750 | 5750 | 24,000 BTU | 3800 | 5000 |
| Washing Machine | 1150 | 2300 | 32,000 BTU | 5000 | 6500 |
| Refrigerator | 700 | 2200 | Room Air Conditioner | | |
| Lights | 100 | 100 | 10,000 BTU | 1500 | 2200 |
| Colour Television | 350 | 350 | Circular Saw 7 1/4" | 1400 | 2300 |
| Electric Frypan | 1500 | 1500 | Chainsaw 2HP | 1100 | 2500 |
| Dehumidifier | 400 | 400 | Portable Air Compressor | 1200 | 3600 |
| Computer - Desktop | 700 | 700 | Hand Drill 1/2" | 600 | 900 |
| VCR | 50 | 50 | Drill 1/2" | 600 | 900 |
| Dishwasher - Cool Dry | 700 | 1400 | Battery Charger - 15 amp | 500 | 700 |
| - Hot Dry | 1450 | 2000 | Electric Welder - 200 amp AC | 9000 | 9000 |
| Toaster - 2 Slice | 1250 | 1250 | Jigsaw | 300 | 400 |
| - 4 Slice | 1600 | 1600 | Electric Weed Trimmer | 500 | 650 |
| Freezer | 2200 | 2500 | Router | 1000 | 1300 |
| Hair Dryer | 800-1700 | 800-1700 | Belt Sander | 1000 | 1300 |
| Steam Iron | 1800 | 1800 | Table Saw 10" | 1750 | 4250 |
| Garage Door Opener - 1/4 HP | 550 | 1100 | Bench Grinder | 1400 | 2450 |
| - 1/3 HP | 725 | 1400 | Concrete Mixer 3.5c/f | 1900 | 2500 |
| Radio | 200 | 200 | Band Saw | 1100 | 1350 |
| Blender | 375 | 500 | Power Drill - Medium | 1000 | 1200 |
| Sump Pump 1/2 HP | 1050 | 2150 | - Heavy Duty | 1500 | 1800 |
| Well Pump 1/2 HP | 1000 | 2100 | Angle Grinder - 100mm | 1000 | 1200 |
| Household Water Pump | 1200 | 2700 | - 230mm | 2400 | 2700 |

This chart lists average power requirements. Your particular tool or appliance may require more or less than the listed wattage. For exact wattages, check the data plate or owner's manual on the item you wish to power. Where START wattage is the same as RUN wattage, this signifies no additional power is required for starting.

Total Running Watts + Highest Starting Watts = Generator Power Needs



CAUTION!

Operating voltage and frequency requirement of all electronic equipment should be checked prior to plugging them into this generator. Damage may result if the equipment is not designed to operate within a +/- 10% voltage variation, and +/- 3 Hz frequency variation from the generator specification ratings.

Calculating Your Power Needs

1. Firstly list all items requiring power simultaneously.
2. Then add up all the “running wattage” requirements for all items.
3. Add to that total the highest of the “starting wattages” you listed down. Now you know approximately how much power you need to start and run your appliances and equipment.

| Tool or Appliance | Running Watts | Starting Watts |
|--------------------------------|---------------|----------------|
| 1. | | |
| 2. | | |
| 3. | | |
| 4. | | |
| 5. | | |
| Total Running Watts | | |
| Highest Starting Watts | | |
| = Generator Power Needs | | |

Operation



WARNING!

Never operate the engine in a closed area or it may cause unconsciousness and death within a short time. Operate the engine in a well ventilated area.



CAUTION!

The generator has been shipped without engine oil. DO NOT start the engine without filling oil to the required level. Do not tilt the generator when adding engine oil. This could result in overfilling and may damage the engine.

DO NOT connect any electric devices before starting the engine.

Standard Atmospheric Conditions

The generator can be used with the rated output load at standard atmospheric conditions.

Ambient Temperature: 25°

Barometric Pressure: 100kPa

Relative Humidity: 30%

The output of the generator varies due to change in temperature, altitude (lower air pressure at higher altitude) and humidity. The output of the generator is reduced when the temperature, the humidity and the altitude are higher than standard atmospheric conditions. Additionally, the load must be reduced when using in confined areas, as generator cooling is affected.

Battery Charging

Start the engine first and allow it to reach idle before connecting the generator to the battery. Battery charging is performed using the 12V DC outlet only.

1. Be sure the ESC switch is turned "OFF" while charging batteries.
2. Be sure to connect the red battery charger lead to the positive (+) battery terminal, and connect the black lead to the negative (-) battery terminal. DO NOT reverse these positions.
3. Connect the battery charger leads to the battery terminals securely so that they are not disconnected due to engine vibration or other disturbances.
4. Charge the battery by following the instructions in the owner's manual for the battery.
5. The DC Circuit Breaker will turn "OFF" automatically if the current exceeds rated output.
6. To restart charging the battery, turn the DC protector on by pressing its button to "ON"
7. Refer to the owner's manual for the battery to determine charging times.

NOTE: *Never start or stop the generator with electric devices plugged in or turned on.*



CAUTION!

The DC terminals may be used for charging 12 volt automotive type batteries only.

Maintenance

| Item | Frequency | Prior to use | First mth or first 20hrs | Every 3mths or 50hrs | Every 12 mths or 100hrs |
|----------------------------------|----------------------|--------------------------------------|--------------------------|----------------------|-------------------------|
| Engine Oil | Check - Refill | ● | | | |
| | Replace | | ● | ● | |
| Reduction Gear Oil (if equipped) | Oil Level Check | ● | | | |
| | Replace | | ● | ● | |
| Air Filter Element | Check | ● | | | |
| | Clean | | ● | | |
| | Replace | | | ● | |
| Deposit Cup (if equipped) | Clean | | | | ● |
| Spark Plug) | Check - Adjust | | | | ● |
| | Replace | Every year or 250 hours of Operation | | | |
| Spark Arrester | Clean | | | ● | |
| Idling (if equipped) * | Check - Adjust | | | | ● |
| Valve Clearance * | Check - Adjust | | | | ● |
| Fuel Tank & Filter * | Clean | | | | ● |
| Fuel Line | Check | Every 2 years (Change if necessary) | | | |
| Cylinder Head Piston | Clean Up Carb - On * | <225cc - Every 125hrs | | | |
| | | >225cc - Every 250hrs | | | |

* Items should be maintained and repaired by an Authorized Powertec Service Supplier.

NOTE: If the generator engine works frequently under high temperature or heavy load, change the oil every 25 hours.

If the engine frequently works under dusty or other severe conditions, clean the air filter element every 10 hours; If necessary, change the air filter element every 25 hours.

While maintaining the generator you should follow the service interval guide above, using the time interval which comes first.

If you have missed the scheduled time to maintain your engine, do it as soon as possible.



WARNING!

Stop the engine before servicing. Place engine on a level surface and remove spark plug cap to prevent engine from starting.

Do not operate engine in a poorly ventilated room or other enclosed area. Be sure to keep good ventilation in working area. The exhaust from engine may contain poisonous CO, inhalation can cause shock, unconsciousness and even death.

Troubleshooting

Engine Problems

| PROBLEM (SYMPTOMS) | RECOMMENDED ACTION | IF PROBLEM PERSISTS |
|--------------------------------------|--|---|
| <p>Engine does not start</p> | <p>1. Turn engine switch to "ON", pull recoil starter.</p> | <p>If all recommended possible areas of misadjustment have been checked and the problem persists, contact your local Powertec Authorised Service Facility</p> |
| | <p>2. Check fuel. Fill if empty. See pg 15 for more information</p> | |
| | <p>3. If oil warning light flickers check oil level. If low, add engine oil. See pg 14 for more information.</p> | |
| | <p>4. Check sparkplug. (TORCHA5RTC) Clean if necessary or adjust/replace gap. Gap: 0.6 - 0.7mm (0.024 - 0.028") See pg 22 for more information</p> | |
| | <p>5. Check fuel filter - See pg 26. Carburettor - See pg 22. Air filter - See pg 24. Maintain/service if necessary.</p> | |
| <p>Generator won't produce power</p> | <p>1. Check safety device (DC protector) is "ON".</p> | |
| | <p>2. Turn safety device (AC) to "OFF". Stop engine and re-start.</p> | |

PT3200i EXPLODED VIEW

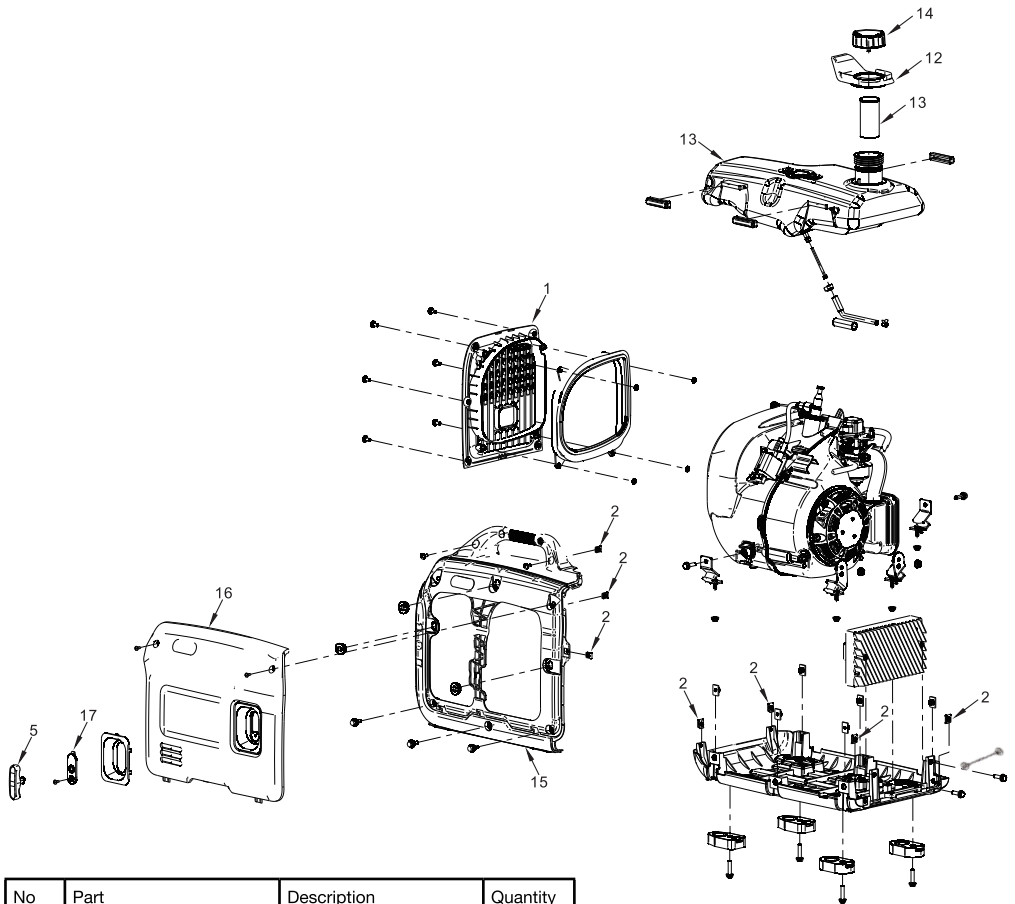

| No | Part | Description | Quantity |
|----|---------------------|------------------------|----------|
| 1 | 469.2420.002V.04.00 | Muffler shield | 1 |
| 2 | 6178.0500.00.04 | Clip nut | 7 |
| 3 | 469.6950.002V.00.01 | Control harness | 1 |
| 4 | 469.2470.001V.00.00 | Inverter | 1 |
| 5 | 148.2000.001V.00.01 | Starting handle | 1 |
| 6 | 469.3370.001V.00.99 | Control panel | 1 |
| 7 | 469.5596.004V.A6.00 | Right exterior cover | 1 |
| 8 | 469.2222.002V.04.00 | Right housing assembly | 1 |
| 9 | 467.4789.001V.00.00 | Step bolt | 3 |
| 10 | 469.4259.001V.A6.00 | Spark plug cover plate | 1 |

PT3200i EXPLODED VIEW

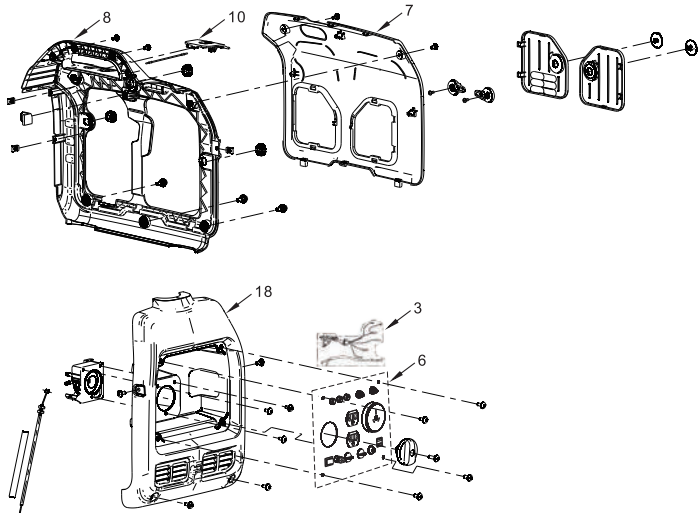

| | | | |
|----|---------------------|--------------------------------|---|
| 11 | 469.3200.001V.00.00 | Fuel tank | 1 |
| 12 | 469.3200.001V.00.03 | Oil filling port rubber sleeve | 1 |
| 13 | 467.3200.001V.00.02 | Fuel filter screen | 1 |
| 14 | 467.3200.004V.00.01 | Fuel tank cap | 1 |
| 15 | 469.2220.002V.04.00 | Left housing assembly | 1 |
| 16 | 469.5596.003V.A6.00 | Left exterior cover | 1 |
| 17 | T48.2186.001V.00.00 | Handle cover plate | 1 |
| 18 | 469.6655.002V.00.00 | Panel seat | 1 |

PT3200i ENGINE VIEW

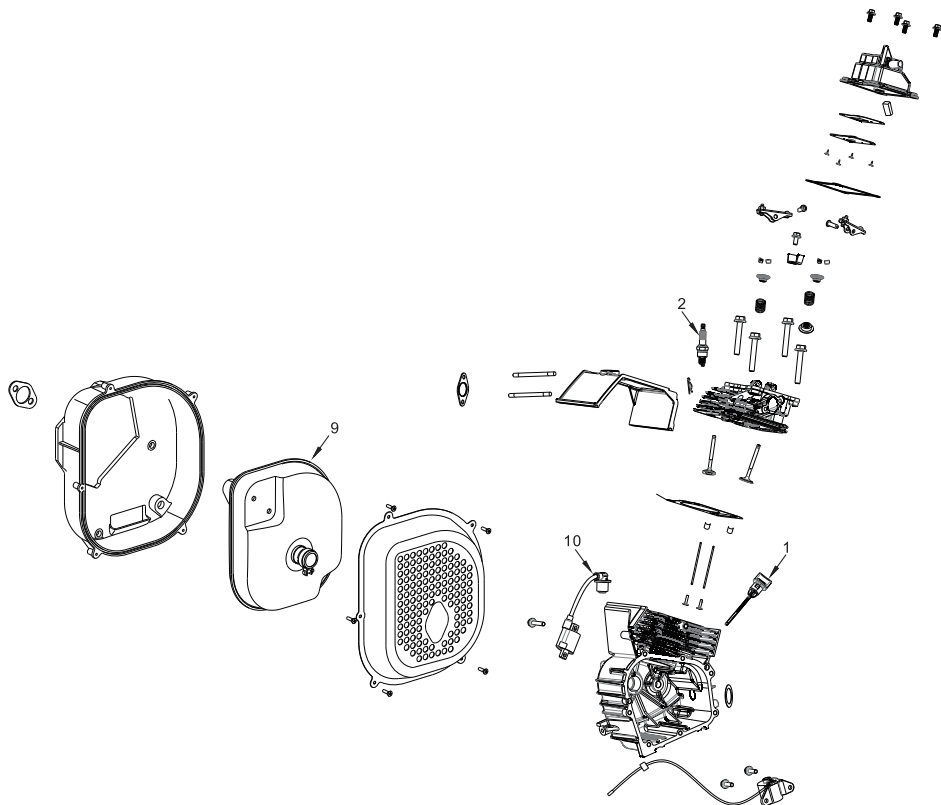

| No | Part | Description | Quantity |
|----|---------------------|------------------|----------|
| 1 | 164.1230.001V.00.00 | Dip Stick | 1 |
| 2 | 148.2160.001V.00.00 | Spark Plug | 1 |
| 3 | 164.2300.001V.00.00 | Carburetor block | 1 |
| 4 | 148.3090.001V.00.00 | Gasket | 1 |
| 5 | 164.2260.C01V.00.00 | Carburetor Assy | 1 |
| 6 | 474.4000.0040.00.00 | Stepper motor | 1 |
| 7 | 164.2410.001V.00.00 | Intake elbow | 1 |
| 8 | 164.2000.001V.00.01 | Wind deflector | 1 |
| 9 | 474.2400.001V.00.00 | Muffler Assy | 1 |
| 10 | 164.1522.002V.00.00 | Ignition Coil | 1 |

PT3200i ENGINE VIEW

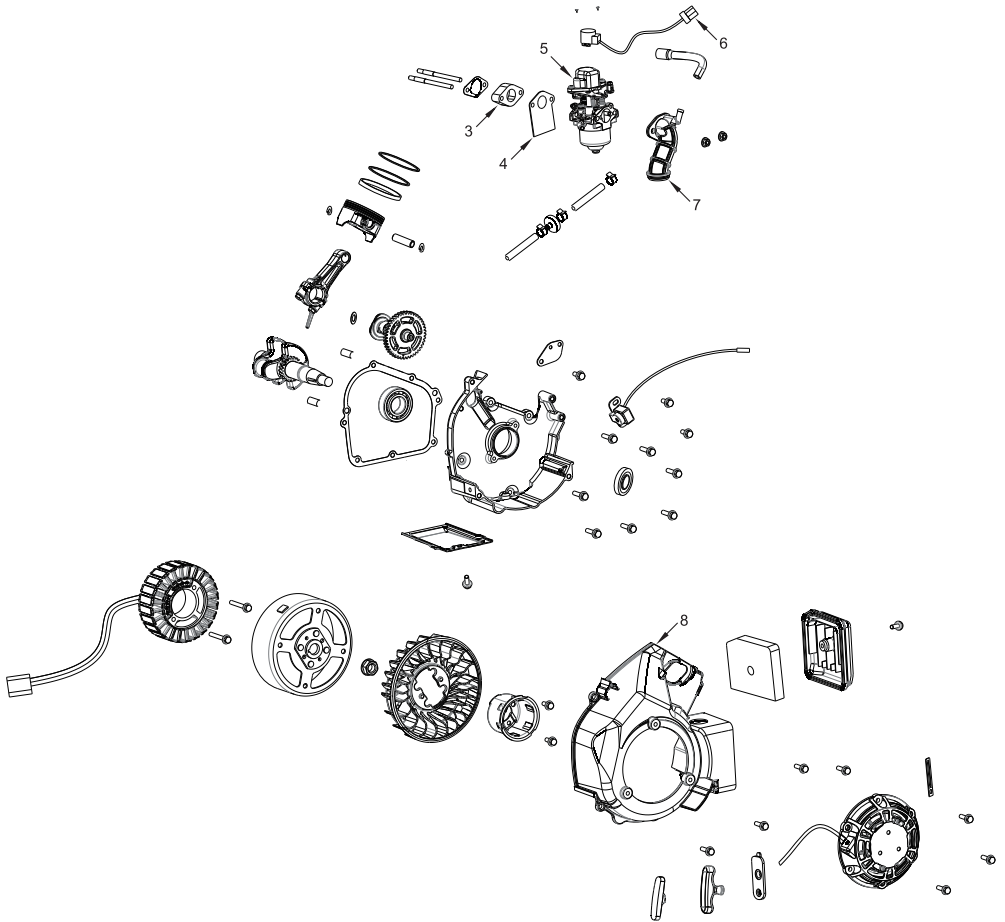

PT3200i SCHEMATICS

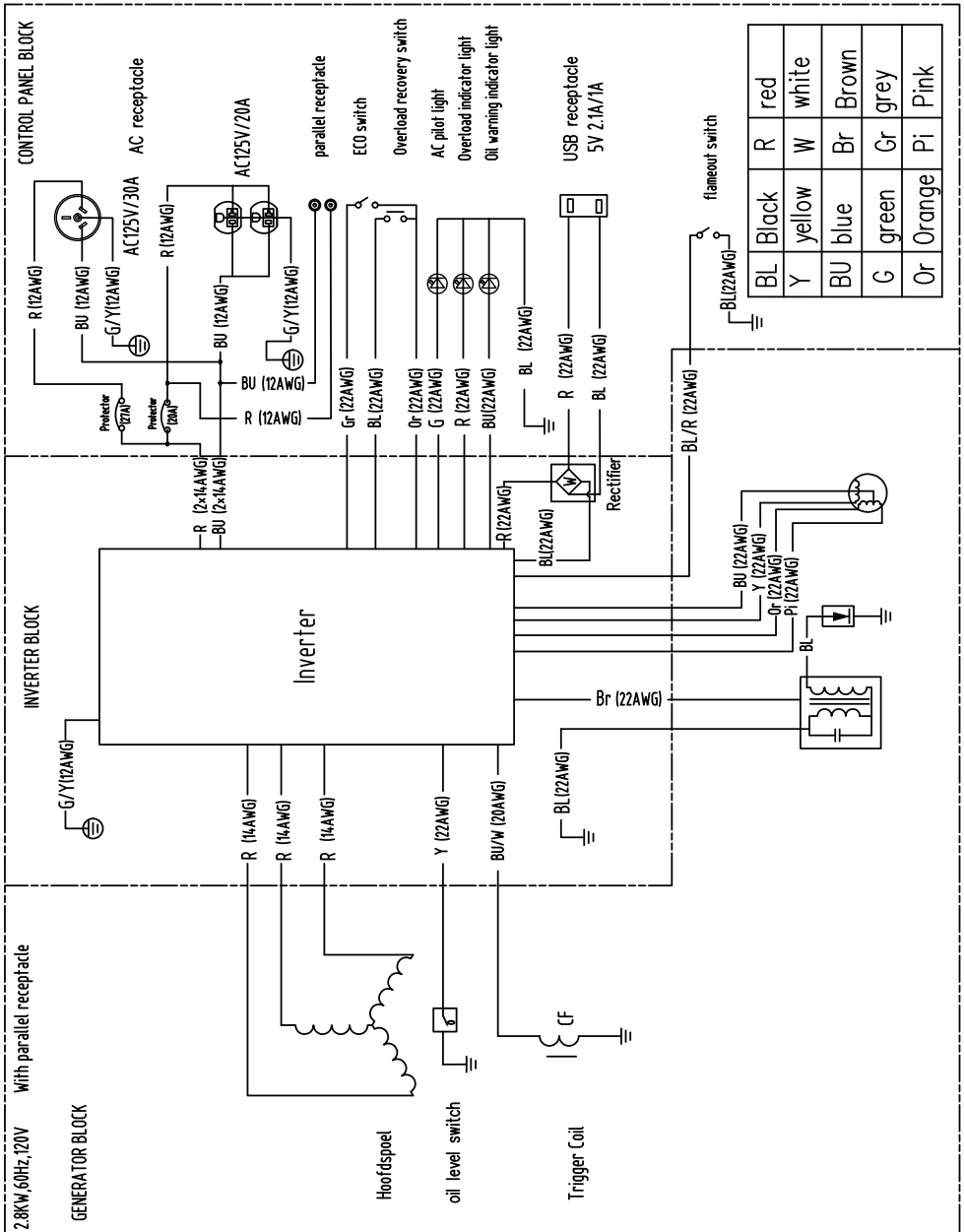

Warranty

As part of an on-going commitment to excellence in product support, Euroquip offers a comprehensive product warranty program. In order to qualify for full warranty support, your product must be registered. Product not registered with Euroquip is supported by a base 12-month warranty only. Spare parts and technical support will not be available for an unregistered product outside of this base warranty period.

If a Euroquip dealer has not already registered your product, please register it online or download a physical registration form at www.euroquip.co.nz.

Registered warranty period for the PT3200i

Commercial Use: 12 Months

Domestic Use: 12 Months

Warranty covers failure caused by manufacturing and material defects in the product, during the warranty period specified. The warranty period begins when the product is purchased by the end user. Warranty is not transferrable and is only claimable by the original purchaser. Warranty does not cover parts that are subject to wear and tear from usage.

Warranty covers failure of a product caused by defective materials and/or manufacturing for the period given and the usage specified by Euroquip. The warranty period begins when the product is purchased by the end user.

Warranty is not transferrable and is only claimable by the original purchaser.

Warranty also does not cover failure caused by the untimely replacement or service of the above wearing parts. Evidence must be provided that the product has been maintained and serviced suitably for a claim to be considered under warranty.

Failure caused by incorrect operation of the product, lack of proper care and maintenance of the product, external damage, external circumstances such as contaminated fuel or poor water supply, modifications to the product, attempted repair/ service by a party other than an Approved Service Agent, is not covered under warranty.

Warranty does not cover pre delivery service and adjustment, or failure that may occur as a result of lack of/ incorrect pre delivery service and adjustment. Warranty does not cover any incidental, indirect or consequential loss, damage or expense that may result from any defect, failure or malfunction of a product.

Should any issue be found to be a combination of a warranty failure and a non-warranty issue, the repair cost component to rectify and repair the non-warranty failure is the customers' full responsibility.

The decision that an issue with a product qualifies as a warranty claim is made at the sole jurisdiction of Euroquip.

No costs incurred will be considered under warranty if repairs are carried out by a party other than a Euroquip Approved Service Agent, unless with prior consent in writing from Euroquip.

It is the responsibility of the purchaser to deliver a product under warranty to the nearest relevant service agent or product reseller. Warranty does not cover call outs, mileage and freight costs.

If a product is repaired under warranty, parts and labour required for the repair will be supplied at no charge. Warranty assessment and repair will be scheduled and executed according to the normal work flow at the service location and depending on the availability of suitable replacement parts.

This warranty policy is an additional benefit and does not affect the legal rights of any end user, reseller or service agent.

Scan here to register your product:



<http://www.euroquip.co.nz/Contact+Us/Product+Registration+Form.html>



Congratulations on your new **POWERTEC** product. We are proud to have you as our customer and will strive to provide you with the best service and reliability in the industry. This product is backed by our extensive warranty and service network. Please contact your local agent or submit a service case online for fast response at www.powertec.net.nz