

weldtech

PROMIG 210

210A - GAS / GASLESS MIG WELDER





We Appreciate Your Business!

Congratulations on your new Weldtech product. We are proud to have you as our customer and will strive to provide you with the best service and reliability in the industry. This product is backed by our extensive warranty and world-wide service network. To locate your nearest distributor or service agency call **0800 387 678**, or email us at **info@euroquip.co.nz**.

This operating manual has been designed to instruct you on the correct use and operation of your Weldtech product. Your satisfaction with this product and its safe operation is our ultimate concern. Therefore, please take time to read the entire manual, especially the Safety Precautions. They will help you to avoid potential hazards that may exist when working with this product.

You Are In Good Company!

Weldtech is a strong Global Brand of Welding Products. We manufacture and supply to major welding industry sectors world-wide including: Manufacturing, Construction, Mining, Automotive, Aerospace, Engineering, Rural and DIY/Hobbyist.

We distinguish ourselves from our competition through market-leading, dependable products that have stood the test of time. We pride ourselves on technical innovation, competitive prices, excellent delivery, superior customer service and technical support, together with excellence in sales and marketing expertise.

Above all, we are committed to develop technologically advanced products to achieve a safer working environment within the welding industry.

⚠ WARNING

Read and understand this entire Manual and your employer's safety practices before installing, operating or servicing the equipment.

While the information contained in this Manual represents the Manufacturer's best judgement, the Manufacturer assumes no liability for its use.

CONTENTS

SECTION 1 - SAFETY INSTRUCTIONS AND WARNINGS

Welding Hazards.....	4
Principal Safety Standards.....	7

CHAPTER 1 - PRODUCT DESCRIPTION

1.1 Product Application.....	8
1.2 Model Specifications.....	8
1.3 Working Conditions.....	8

CHAPTER 2 - INSTALLING

2.1 Working Conditions.....	9
2.2 Pre-assembly check.....	9
2.3 Installing the Wheels.....	9
2.4 Installing the Handle.....	10
2.5 Installing the Clamp.....	10
2.6 Connecting the Torch Cable.....	10
2.7 Installing the Wire Spool.....	11
2.8 Feeding the Wire.....	11
2.9 Setting Wire Tension.....	12
2.10 Adjusting the Clutch.....	12
2.11 Turning/changing the Drive Roller.....	13
2.12 Preparing the Shielding Gas.....	13
2.13 Regulator Warnings.....	14

CHAPTER 3 - OPERATION

3.1 Control Panel.....	15
3.2 Graphic Symbols and Technical Data.....	16
3.3 Operation Process.....	16
3.4 Basic Welding Technique.....	18
3.5 Technical Tips.....	20

CHAPTER 4 - TROUBLE SHOOTING

4.1 Basic Troubleshooting.....	21
4.2 Solving Problems Beyond the Welding Terminals.....	21
4.3 Solving Welding Problems.....	23

CHAPTER 5 - MAINTENANCE

5.1 Maintenance.....	25
----------------------	----

CHAPTER 6 - ASSEMBLY

6.1 Assembly Drawing.....	26
---------------------------	----

CHAPTER 7 - ASSEMBLY

7.1 Parts List.....	27
7.2 Pack List.....	27

SECTION 1: SAFETY INSTRUCTIONS AND WARNINGS

WARNING

PROTECT YOURSELF AND OTHERS FROM POSSIBLE SERIOUS INJURY OR DEATH. KEEP CHILDREN AWAY. PACEMAKER WEARERS KEEP AWAY UNTIL CONSULTING YOUR DOCTOR. DO NOT LOSE THESE INSTRUCTIONS. READ OPERATING/INSTRUCTION MANUAL BEFORE INSTALLING, OPERATING OR SERVICING THIS EQUIPMENT.

Welding products and welding processes can cause serious injury or death, or damage to other equipment or property, if the operator does not strictly observe all safety rules and take precautionary actions.

Safe practices have developed from past experience in the use of welding and cutting. These practices must be learned through study and training before using this equipment. Some of these practices apply to equipment

connected to power lines; other practices apply to engine driven equipment. Anyone not having extensive training in welding and cutting practices should not attempt to weld.

Safe practices are outlined in the American National Standard Z49.1 entitled: SAFETY IN WELDING AND CUTTING. This publication and other guides to what you should learn before operating this equipment are listed at the end of these safety precautions. **HAVE ALL INSTALLATION, OPERATION, MAINTENANCE, AND REPAIR WORK PERFORMED ONLY BY QUALIFIED PEOPLE.**

1.01 Arc Welding Hazards



WARNING

ELECTRIC SHOCK can kill.

Touching live electrical parts can cause fatal shocks or severe burns. The electrode and work circuit is electrically live whenever the output is on. The input power circuit and machine internal circuits are also live when power is on. In semiautomatic or automatic wire welding, the wire, wire reel, drive roll housing, and all metal parts touching the welding wire are electrically live. Incorrectly installed or improperly grounded equipment is a hazard.

1. Do not touch live electrical parts.
2. Wear dry, hole-free insulating gloves and body protection.
3. Insulate yourself from work and ground using dry insulating mats or covers.
4. Disconnect input power or stop engine before installing or servicing this equipment. Lock input power disconnect switch open, or remove line fuses so power cannot be turned on accidentally.
5. Properly install and ground this equipment according to its Owner's Manual and national, state, and local codes.
6. Turn off all equipment when not in use. Disconnect power to equipment if it will be left unattended or out of service.

7. Use fully insulated electrode holders. Never dip holder in water to cool it or lay it down on the ground or the work surface. Do not touch holders connected to two welding machines at the same time or touch other people with the holder or electrode.
8. Do not use worn, damaged, undersized, or poorly spliced cables.
9. Do not wrap cables around your body.
10. Ground the workpiece to a good electrical (earth) ground.
11. Do not touch electrode while in contact with the work (ground) circuit.
12. Use only well-maintained equipment. Repair or replace damaged parts at once.
13. In confined spaces or damp locations, do not use a welder with AC output unless it is equipped with a voltage reducer. Use equipment with DC output.
14. Wear a safety harness to prevent falling if working above floor level.
15. Keep all panels and covers securely in place.



WARNING

ARC RAYS can burn eyes and skin; NOISE can damage hearing. Arc rays from the welding process produce intense heat and strong ultraviolet rays that can burn eyes and skin. Noise from some processes can damage hearing.

1. Wear a welding helmet fitted with a proper shade of filter (see ANSI Z49.1 listed in Safety Standards) to protect your face and eyes when welding or watching.
2. Wear approved safety glasses. Side shields recommended.

3. Use protective screens or barriers to protect others from flash and glare; warn others not to watch the arc.
4. Wear protective clothing made from durable, flame-resistant material (wool and leather) and foot protection.
5. Use approved ear plugs or ear muffs if noise level is high.



WARNING

FUMES AND GASES can be hazardous to your health.

Welding produces fumes and gases. Breathing these fumes and gases can be hazardous to your health.

1. Keep your head out of the fumes. Do not breathe the fumes.
2. If inside, ventilate the area and/or use exhaust at the arc to remove welding fumes and gases.
3. If ventilation is poor, use an approved air-supplied respirator.
4. Read the Material Safety Data Sheets (MSDSs) and the manufacturer's instruction for metals, consumables, coatings, and cleaners.
5. Work in a confined space only if it is well ventilated, or while wearing an air-supplied respirator. Shielding gases used for welding can displace air causing injury or death. Be sure the breathing air is safe.
6. Do not weld in locations near degreasing, cleaning, or spraying operations. The heat and rays of the arc can react with vapors to form highly toxic and irritating gases.
7. Do not weld on coated metals, such as galvanized, lead, or cadmium plated steel, unless the coating is removed from the weld area, the area is well ventilated, and if necessary, while wearing an air-supplied respirator. The coatings and any metals containing these elements can give off toxic fumes if welded.



WARNING

WELDING can cause fire or explosion.

Sparks and spatter fly off from the welding arc. The flying sparks and hot metal, weld spatter, hot workpiece, and hot equipment can cause fires and burns. Accidental contact of electrode or welding wire to metal objects can cause sparks, overheating, or fire.

1. Protect yourself and others from flying sparks and hot metal.
2. Do not weld where flying sparks can strike flammable material.
3. Remove all flammables within 35 ft (10.7 m) of the welding arc. If this is not possible, tightly cover them with approved covers.
4. Be alert that welding sparks and hot materials from welding can easily go through small cracks and openings to adjacent areas.
5. Watch for fire, and keep a fire extinguisher nearby.
6. Be aware that welding on a ceiling, floor, bulkhead, or partition can cause fire on the hidden side.
7. Do not weld on closed containers such as tanks or drums.
8. Connect work cable to the work as close to the welding area as practical to prevent welding current from traveling long, possibly unknown paths and causing electric shock and fire hazards.
9. Do not use welder to thaw frozen pipes.
10. Remove stick electrode from holder or cut off welding wire at contact tip when not in use.

Eye protection filter shade selector for welding or cutting (goggles or helmet), from AWS/ANSI Z49.1:1999					
Welding or Cutting Operation	Electrode Size Metal Thickness or Welding	Filter Shade	Welding or Cutting Operation	Electrode Size Metal Thickness or Welding	Filter Shade
Torch Soldering	All	2	Gas Tungsten Arc Welding		
Torch Brazing	All	3 or 4	Light	Under 50 Amp	10
Oxygen Cutting			Medium	50 to 150 Amp	12
Light	Under 1 in., 25 mm	3 or 4	Heavy	150 to 500 Amp	14
Medium	1 – 6 in., 25 – 150 mm	4 or 5	Atomic Hydrogen Welding		
Heavy	Over 6 in., 150 mm	5 or 6	Carbon Arc Welding		
Gas Welding			Carbon Arc Gouging		
Light	Under 1/8 in., 3 mm	4 or 5	Light		12
Medium	1/8 – 1/2 in., 3 – 12 mm	5 or 6	Heavy		14
Heavy	Over 1/2 in., 12 mm	6 or 8	Plasma Arc Welding		
Shielded Metal-Arc Welding (Stick) Electrodes			Light	Under 20 Amp	6 to 8
Light	Under 5/32 in., 4 mm	10	Light	20 to 100 Amp	10
Medium	Under 5/32 to 1/4 in., 4 to 6.4mm	12	Medium	100 to 400 Amp	12
Heavy	Over 1/4 in., 6.4 mm	14	Heavy	400 to 800 Amp	14
Gas Metal Arc Welding			Plasma Arc Cutting		
Light	Under 60 Amp	7	Light	Under 300 Amp	9
Light	60 to 160 Amp	11	Medium	300 to 400 Amp	12
Medium	160 to 250 Amp	12	Heavy	400 to 800 Amp	14
Heavy	250 to 500 Amp	14			



WARNING

FLYING SPARKS AND HOT METAL can cause injury.

Chipping and grinding cause flying metal. As welds cool, they can throw off slag.

1. Wear approved face shield or safety goggles. Side shields recommended.
2. Wear proper body protection to protect skin.



WARNING

CYLINDERS can explode if damaged.

Shielding gas cylinders contain gas under high pressure. If damaged, a cylinder can explode. Since gas cylinders are normally part of the welding process, be sure to treat them carefully.

1. Protect compressed gas cylinders from excessive heat, mechanical shocks, and arcs.
2. Install and secure cylinders in an upright position by chaining them to a stationary support or equipment cylinder rack to prevent falling or tipping.
3. Keep cylinders away from any welding or other electrical circuits.
4. Never allow a welding electrode to touch any cylinder.
5. Use only correct shielding gas cylinders, regulators, hoses, and fittings designed for the specific application; maintain them and associated parts in good condition.
6. Turn face away from valve outlet when opening cylinder valve.
7. Keep protective cap in place over valve except when cylinder is in use or connected for use.
8. Read and follow instructions on compressed gas cylinders, associated equipment, and CGA publication P-1 listed in Safety Standards.



WARNING

Engines can be dangerous.



WARNING

ENGINE EXHAUST GASES can kill.

Engines produce harmful exhaust gases.

1. Use equipment outside in open, well-ventilated areas.

2. If used in a closed area, vent engine exhaust outside and away from any building air intakes.



WARNING

ENGINE FUEL can cause fire or explosion.

Engine fuel is highly flammable.

1. Stop engine before checking or adding fuel.
2. Do not add fuel while smoking or if unit is near any sparks or open flames.
3. Allow engine to cool before fueling. If possible, check and add fuel to cold engine before beginning job.
4. Do not overfill tank — allow room for fuel to expand.
5. Do not spill fuel. If fuel is spilled, clean up before starting engine.



WARNING

MOVING PARTS can cause injury.

Moving parts, such as fans, rotors, and belts can cut fingers and hands and catch loose clothing.

1. Keep all doors, panels, covers, and guards closed and securely in place.
2. Stop engine before installing or connecting unit.
3. Have only qualified people remove guards or covers for maintenance and troubleshooting as necessary.
4. To prevent accidental starting during servicing, disconnect negative (-) battery cable from battery.
5. Keep hands, hair, loose clothing, and tools away from moving parts.
6. Reinstall panels or guards and close doors when servicing is finished and before starting engine.



WARNING

SPARKS can cause BATTERY GASES TO EXPLODE; BATTERY ACID can burn eyes and skin.

Batteries contain acid and generate explosive gases.

1. Always wear a face shield when working on a battery.
2. Stop engine before disconnecting or connecting battery cables.
3. Do not allow tools to cause sparks when working on a battery.
4. Do not use welder to charge batteries or jump start vehicles.
5. Observe correct polarity (+ and -) on batteries.



WARNING

STEAM AND PRESSURIZED HOT COOLANT can burn face, eyes, and skin.

The coolant in the radiator can be very hot and under pressure.

1. Do not remove radiator cap when engine is hot. Allow engine to cool.
2. Wear gloves and put a rag over cap area when removing cap.
3. Allow pressure to escape before completely removing cap.



WARNING

This product, when used for welding or cutting, produces fumes or gases which contain chemicals known to the State of California to cause birth defects and, in some cases, cancer. (California Health & Safety code Sec. 25249.5 et seq.)

NOTE

Considerations About Welding And The Effects of Low Frequency Electric and Magnetic Fields

The following is a quotation from the General Conclusions Section of the U.S. Congress, Office of Technology Assessment, Biological Effects of Power Frequency Electric & Magnetic Fields - Background Paper, OTA-BP-E-63 (Washington, DC: U.S. Government Printing Office, May 1989): "...there is now a very large volume of scientific findings based on experiments at the cellular level and from studies with animals and people which clearly establish that low frequency magnetic fields and interact with, and produce changes in, biological systems. While most of this work is of very high quality, the results are complex. Current scientific understanding does not yet allow us to interpret the evidence in a single coherent framework. Even more frustrating, it does not yet allow us to draw definite conclusions about questions of possible risk or to offer clear science-based advice on strategies to minimize or avoid potential risks."

To reduce magnetic fields in the workplace, use the following procedures.

1. Keep cables close together by twisting or taping them.
2. Arrange cables to one side and away from the operator.
3. Do not coil or drape cable around the body.
4. Keep welding power source and cables as far away from body as practical.

ABOUT PACEMAKERS:

The above procedures are among those also normally recommended for pacemaker wearers. Consult your doctor for complete information.

1.02 Principal Safety Standards

Safety in Welding and Cutting, ANSI Standard Z49.1, from American Welding Society, 550 N.W. LeJeune Rd., Miami, FL 33126.

Safety and Health Standards, OSHA 29 CFR 1910, from Superintendent of Documents, U.S. Government Printing Office, Washington, D.C. 20402.

Recommended Safe Practices for the Preparation for Welding and Cutting of Containers That Have Held Hazardous Substances, American Welding Society Standard AWS F4.1, from American Welding Society, 550 N.W. LeJeune Rd., Miami, FL 33126.

National Electrical Code, NFPA Standard 70, from National Fire Protection Association, Batterymarch Park, Quincy, MA 02269.

Safe Handling of Compressed Gases in Cylinders, CGA Pamphlet P-1, from Compressed Gas Association, 1235 Jefferson Davis Highway, Suite 501, Arlington, VA 22202.

Code for Safety in Welding and Cutting, CSA Standard W117.2, from Canadian Standards Association, Standards Sales, 178 Rexdale Boulevard, Rexdale, Ontario, Canada M9W 1R3.

Safe Practices for Occupation and Educational Eye and Face Protection, ANSI Standard Z87.1, from American National Standards Institute, 1430 Broadway, New York, NY 10018.

Cutting and Welding Processes, NFPA Standard 51B, from National Fire Protection Association, Batterymarch Park, Quincy, MA 02269.

1.1 Product Application

The Weldtech PROMIG 210 incorporates the latest technology in transformer Mig Welding. The heavy duty wire feed unit combines with a state of the art power transformer to produce excellent welding results across a broad range of applications.

1.2 Model Specifications

WELDTECH PROMIG 210			
Rated Input Voltage:	230V		
Frequency:	50Hz		
Phase:	Single		
Max. Input Capacity:	9kVA		
No-load Voltage: (peak value)	26 - 50VDC		
Voltage Setting:	3	4	6
Rated Output Current:	80A	105A	210A
Rated Output Voltage:	18V	19.2V	24.5V
*Duty Cycle:	100%	60%	15%
Insulation Grade:	H		
Power Supply Circuit Breaker Specification: (User-allocated)	40A		
Weight:	44kg		
Dimensions:	800 x 460 x 686mm		

***Duty Cycle** is the ratio of the interrupted on-load duration to the total time (10 minutes here). It is expressed as a percentage. For example, in the case of a 60% duty cycle, a load is applied continuously for 6 mins followed by a no-load period of 4 mins.

- Note:**
1. The heating test of the welding power source is carried out at ambient temperature. Duty cycle at 40°C has been determined by simulation.
 2. The welding power source belongs to Group 2 and Class B ISM equipment according to CISPR 11:2003.

1.3 Working Conditions

- a.) Range of the temperature of the ambient air:
During welding: -10°C to +40°C
After transport and storage at: -25°C to +55°C
- b.) Relative humidity of the air:
Up to 50% at 40°C
Up to 90% at 20°C
- c.) Ambient air, free from abnormal amounts of dust, acids, corrosive gases or substances etc, other than those generated by the welding process.
- d.) Altitude above sea level up to 1000m
- e.) Base of the welding power source include up to 15°.

2.1 Working Conditions

Even ground is necessary to the machine's operation. The workshop must have good ventilation and can't be exposed to dust, dirt, wet or active steam.

2.2 Pre-assembly Check

1. After receiving the equipment, you should check if the equipment has been damaged during transport. If damaged you should notify the freight company immediately.
2. Take the spare parts out from packaging box, remove the packing material and check if anything is left in packing box.
3. Check every airway in the shell, and make sure packing box can't block air circulating.
4. Choose roomy ground to place spare parts in order to install conveniently.

2.3 Installing the wheel: (Refer to Diagram 2-1) The wheels are more easily assembled with the welder placed upside down on a smooth non-abrasive surface. The welder should be turned over by two people as it is very heavy.

1. Bolt the two castors (1) to the front end of the base (2) using the bolts provided.
2. Take the solid axle (3) and slide a wheel (4) over one end followed by a washer (5). Insert a split pin (6) through the hole in one end of the axle as shown below and bend it over.
3. Take an axle retaining bracket (7) and insert it into the slots in the base (2). Hold the bracket in place and slide the axle assembly through both parts of the bracket. Insert the second axle retaining bracket (7) through the base and continue to slide the axle across so that it passes through the second bracket and holds the wheel (4) up against the side of the base. Slide the second wheel (8) onto the free end of the axle followed by a washer (9). Retain the entire axle assembly by passing a split pin (10) through the free end of the axle and bend it over to retain the whole axle assembly.
4. With the assistance of another person turn the welder the right way up onto its wheels.

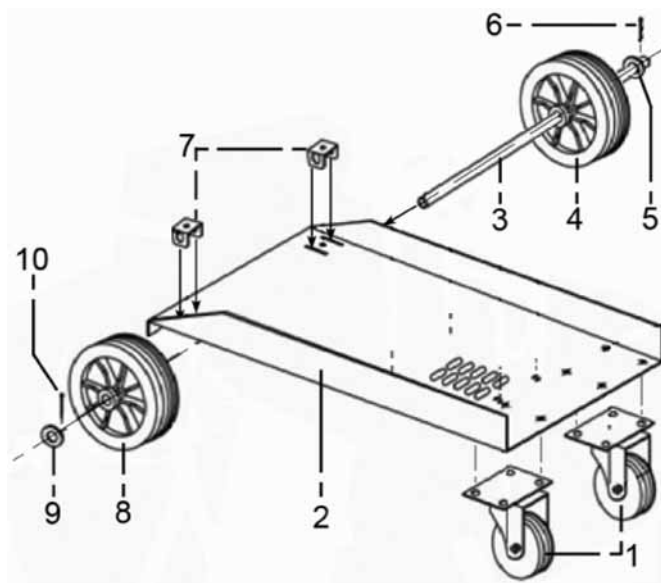

Diagram 2-1

2.4 Installing the handle: (Refer to Diagram 2-2) On the front of the welder there are two pairs of threaded inserts, one pair in the top left corner and one pair in the top right hand corner.

1. Attach the left hand handle mounting (1) to the front of the welder using two of the round headed bolts provided. Do not fully tighten yet.
2. Slide the handle tube (2) into the socket in the mounting and push fully home.
3. Slide the socket on the right hand handle mounting (3) over the free end of the handle tube and rotate the mounting downwards until it is resting on the front of the welder. Using two of the round headed bolts provided to fix the right hand mounting in place.
4. Now fully tighten all four fixings.

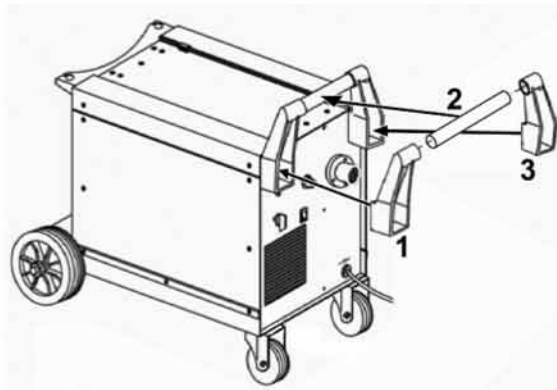

Diagram 2-2

2.5 Installing the clamp: (Refer to Diagram 2-3) Feed the eyelet on the end of the earth lead through the hole in the clamp arm. Drop the eyelet over the terminal and firmly fix with the bolt provided.

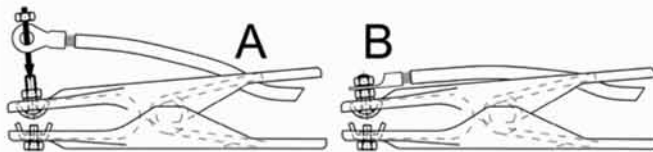

Diagram 2-3

2.6 Connect the torch cable to the welder: (Refer to Diagram 2-4) Align the pins on the Euro connector with the socket on the welder front panel as shown in Diagram 2-4A. Push the connector into the socket and rotate the locking ring (A) clockwise so that it draws the plug into the socket as shown in Diagram 2-4B.



Diagram 2-4

2.7 Installing the spool of wire: The welder will accept either a 5kg or a 15kg reel of wire. Ensure that the wire diameter used, is matched by the correct groove size in the drive wheel and the correct tip size on the torch as well as the correct torch liner. Failure to do this could cause the wire to slip and/or bind.

Unscrew the locking knob from the end of the spool holder (see Diagram 2-5A) and remove the spacer. Slide the reel of wire onto the spool holder and ensure that the clutch pin at the back of the spool holder engages into the guide hole in the wire reel moulding. This will prevent the wire reel from freewheeling on the spool holder. When using a 5kg reel, slide the spacer onto the spool holder before refixing the locking knob. Ensure that the wire is coming off the top of the reel in the direction of the wire drive unit as shown in diagram 2-5B which shows a 15kg reel of wire in place on the spool holder.

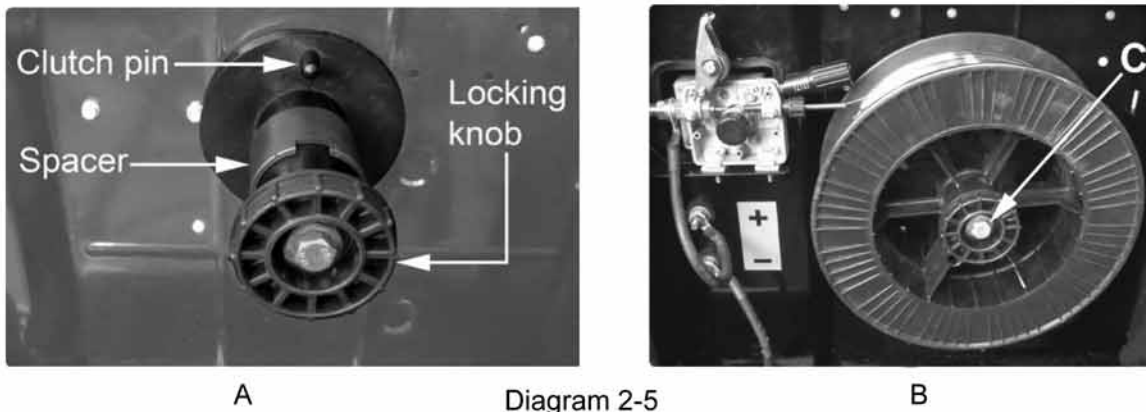

2.8 Feed wire through to torch: (Refer to Diagram 2-6) Open the wire feed mechanism by pushing the locking/wire tension knob (1) down to the right allowing the pressure roller carrier (2) to spring up revealing the feed roller as shown in diagram 2-6A.

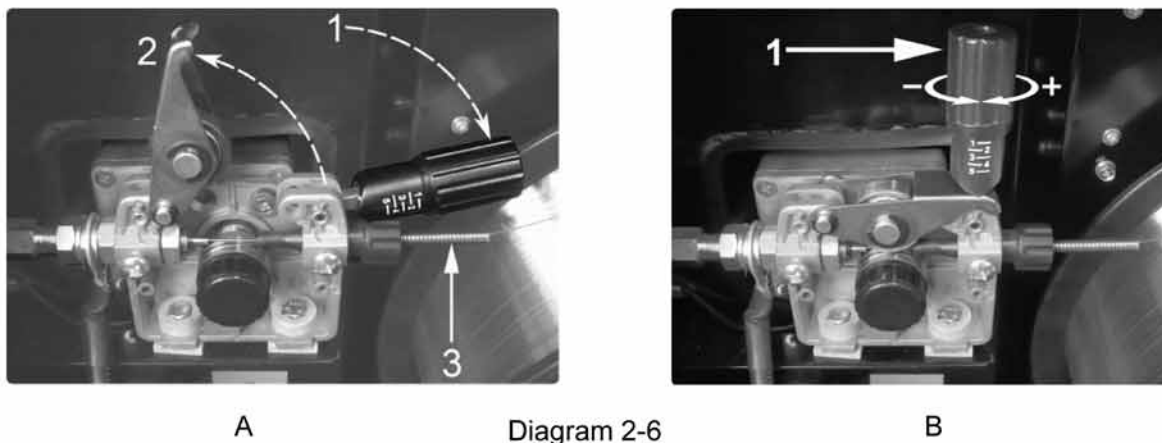

1. Ensure that the required feed groove (0.6 or 0.8) is in line with the wire path. See Section 2.11 on how to reverse or change the roller.
2. Release the wire from the reel and cut off any bent portion ensuring that there are no burrs left on the end of the wire. Keep the wire under tension at all times to prevent it uncoiling.
3. Straighten about 40-50mm of wire and gently push it through the flexible metal sheathed cable (3) and through the 0.6 or 0.8mm feed roller groove and into the torch cable liner.

4. Push down the pressure roller carrier onto the wire feed roller and hold it down. Lift up the locking/wire tension knob so that it enters the slot in the pressure roller carrier and snaps into the indent in its top surface. See diagram 2-6B. Rotate the tension knob to a medium setting i.e. between 2 and 3.
5. Remove gas cup (Diagram 2-7) and contact tip (1) from end of torch as follows:
 - a) Take torch in left hand with the torch tip facing to the right.
 - b) Grasp gas cup firmly in your right hand.
 - c) Turn gas cup clockwise only and pull it off end of torch tip.

WARNING! Do not turn gas cup anti-clockwise, as this will damage the internal spring.

 - d) Unscrew copper contact tip (right hand thread) to remove.

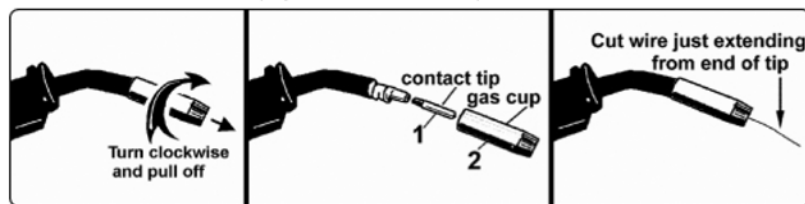

Diagram 2-7

6. Check welder is switched off "0", and that the earth clamp is away from the torch tip. Connect the welder to the mains power supply and set the voltage switch to one.
7. Set the wire speed knob to position 5 or 6. Keep the torch cable as straight as possible and press the torch switch. The wire will feed through the torch.
8. When the wire has fed through, switch welder off, unplug from mains.
 - a) Take torch in left hand, slide the contact tip over the wire and screw back into place.
 - b) Grasp gas cup in right hand, push onto torch head and turn clockwise only. Do not turn gas cup anti-clockwise, as this will damage the internal spring.
 - c) Cut wire so that it is just protruding from the cup.

2.9 Setting wire tension:

1. Adjust the wire tension by rotating the wire tension knob. Turn clockwise to increase the tension and anticlockwise to decrease the tension. See (1) in diagram 2-6A.

IMPORTANT: Too little or too much tension will cause problematic wire feed and result in poor welding.
2. Tension between rollers is checked by slowing down the wire between gloved fingers. If top feed roller skids the tension is correct. Use as low a tension as possible, too high a tension will disfigure wire and result in a blown fuse.

2.10 Clutch adjustment:

Note: It is essential that the clutch is adjusted correctly.

1. Once the wire is fed through the torch, switch on the machine and set the wire speed to maximum.
2. Depress torch switch and release quickly. If the spool overruns it indicates that the clutch is too loose.
3. Tighten the clutch nut located in the centre of the wire spool holder with a spanner (diagram 2-5B-C) and test the machine as above until the wire stops over running.

Note: Do not over tighten the clutch as this will cause wire feed problems and strain the

2.11 Turning changing the drive roller: (Refer to Diagram 2-8) Ensure that the wire diameter used is matched by the correct groove size in the drive wheel and the correct tip size on the torch as well as the correct torch liner. Failure to do this could cause the wire to slip and/or bind.

1. Referring to diagram 2-8, open the wire feed mechanism by pushing the locking/wire tension knob (1) down to the right allowing the pressure roller carrier (2) to spring up revealing the feed roller.
2. Referring to diagram 2-8, loosen and unscrew the black feed roller retaining knob (C) and put to one side.
3. The roller carrier (A) is keyed to the main drive shaft and the drive roller (B) is keyed to the carrier, see below. Place a finger onto the end of the drive shaft to prevent the carrier moving and slide the drive roller off the carrier with your other hand.
4. The size of each wire feed groove is printed on the edge of the roller on the same side as the groove.
5. Turn the roller over to use the other groove or use a roller with different sized grooves as required. The groove to be used should be positioned furthest away from you to be in line with the drive path.
6. Check that the key in the carrier (A) is properly seated in its slot. Ensure that the slot on the inside face of the drive roller (B) is aligned with the key and slide the roller back onto the carrier.
7. Screw the black roller retaining knob (C) back on to the end of the drive shaft and tighten.

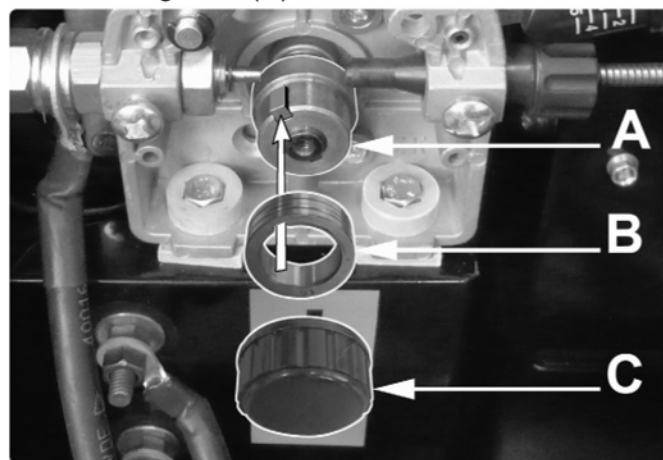

Diagram 2-8

2.12 Preparing the Shielding Gas (For Gas Metal Arc Welding Processes)

Customer must provide cylinder of appropriate type shielding gas, a gas flow regulator, for Argon blend gas, an inlet gas hose, a gas hose, and two stainless steel hose for the process being used. When using 100% CO₂ an additional adapter will be required to connect the regulator to the gas bottle.

Install shielding gas supply as follows:

1. Set gas cylinder on rear platform of Welder. Hook chain in place to secure cylinder to rear of welder.
2. Remove the cylinder cap. Inspect the cylinder valves and regulator for damaged threads, dirt, dust, oil or grease. Remove dust and dirt with a clean cloth.

2.13 Regulator Warnings

DO NOT ATTACH THE REGULATOR IF OIL, GREASE OR DAMAGE IS PRESENT! Inform your gas supplier of this condition. Oil or grease in the presence of high pressure oxygen is explosive.

3. Stand to one side away from the outlet and open the cylinder valve for an instant. This blows away any dust or dirt which may have accumulated in the valve outlet.

Be sure to keep your face away from the valve outlet when “cracking” the valve.

4. Check your regulator to make sure that it was supplied with a gasket. Tighten the regulator coupling to the cylinder gas valve.

NOTE: If connecting to 100% CO₂ cylinder, an additional regulator adapter must be installed between the regulator and cylinder valve. If adapter is equipped with a plastic washer, be sure it is seated for connection to the CO₂ cylinder.

5. Connect one end of the inlet gas hose (not include) to the outlet fitting of the flow regulator, the other end to the Welder rear fitting, a stainless steel hose clamp can be used to insure a leak-proof connection.
6. Before opening the cylinder valve, turn the regulator adjusting knob counterclockwise until the adjusting spring pressure is released.
7. Standing to one side, open the cylinder valve slowly a fraction of a turn. When the cylinder pressure gauge pointer stops moving, open the valve fully.

Never stand directly in front of or behind the flow regulator when opening the cylinder valve. Always stand to one side.

8. The flow regulator is adjustable. Adjust it to the flow rate recommended for the procedure and process being used before making the weld.



Cautions

Do not operate the machine when the shell has been opened, improper cooling can damage the parts; make sure the side board have been closed. When welding, you must wear helmet, glove and other guard.

3.1 Layout drawing of control panel (diagram 3-1)

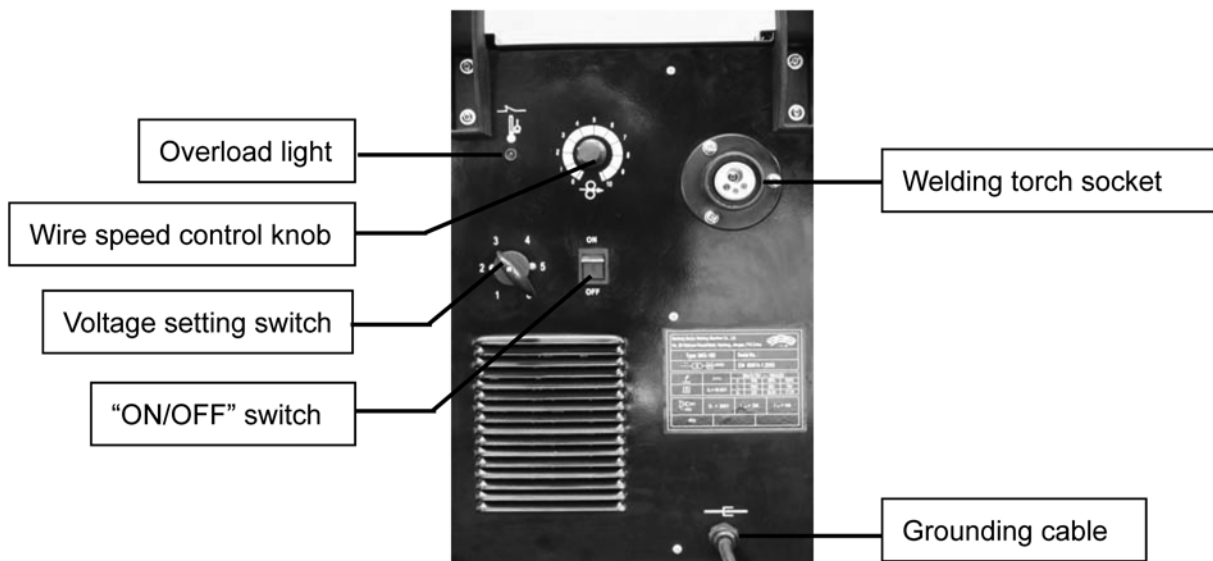

Diagram 3-1

3.1.1 "ON/OFF" switch

When the switch on "OFF" position means power has been closed, when the switch on "ON" position means supply power for the main transformer and control circuit.

3.1.2 Voltage setting switch

Voltage setting switch is at the front panel of machine, it have six shelves, and you can choose different shelves according to the metal material.





3.1.3 Wire speed control knob

Controls the wire speed, turn it clockwise to increase the wire speed or counter-clockwise to decrease the wire speed. The Number 0~10 around knob only show the wire feed speed, rated wire feed speed is 1.8m/min ~ 11.6m/min.

3.1.4 Overload light

If welding with large current for a long time and exceed the duty cycle, the overload lamp will light, the welder will turn off until it cools down. If this happens, you must stop welding and wait about 10 minutes, then you can continue.

3.2 Graphic symbols and technical data

$U_{0.....V}$	This symbol shows the secondary no-load voltage (in volts).
X	This symbol shows the rated duty cycle.
$I_{2.....A}$	This symbol shows the welding current in AMPS.
$U_{2.....V}$	This symbol shows the welding voltage in VOLTS.
U_1	This symbol shows the rated supply voltage.
$I_{1max...A}$	This symbol shows the welding unit's maximum absorbed current in AMP.
$I_{1eff...A}$	This symbol shows the welding unit's maximum effective supply current in AMP.
IP21	This symbol shows the welding unit's protection class.
	This symbol shows that the welding unit is suitable for use in environments where there is a high risk of electric shocks.
	This symbol shows read the operating instructions carefully before operation.
	This symbol shows a single phase transformer rectifier welder.
	This symbol shows the supply power phase and line frequency in Hertz.
	This symbol shows the welder is metal inert and active gas welding including the use of flux cored wire.

3.3 Operation process

Before Welding

- Read and understand the safety rules section of this manual.
- Be sure all flammable materials are removed the work area.
- There is good ventilation around the welding unit and the area that you will be working.
- Be sure you have fire-extinguisher ready in case of an accident.
- Put on appropriate protective clothing and insulated leather gloves.

3.3.1 Use with cored wire

The welder can used with special Flux wire that dose not require protective gas. This wire, contrary to the case with electrodes, does not leave slag and gives better bread penetration with substantially lower line absorption.

Make sure you use proper welding polarity: as diagram 3-2B. Grounding cable connects "+" terminal, another cable (welding torch cable) connect "-" terminal.

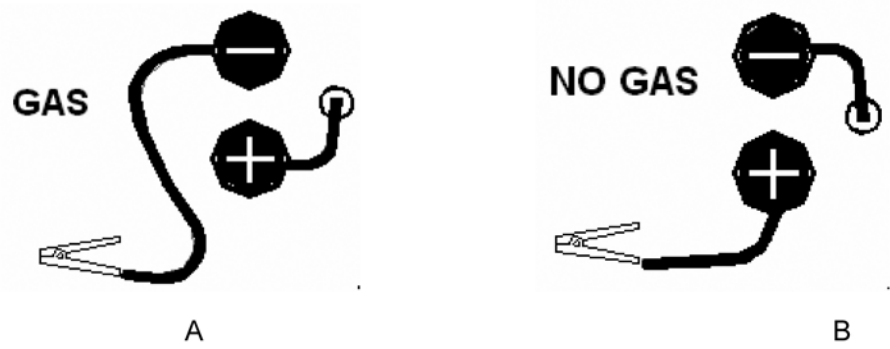

Diagram 3-2

Step1: Connect work clamp onto metal to be welded, or to the metal workbench where the object is mounted and electrically connected.

Step2: Before plugging in, adjust amperage and wire feed speed according to material type and thickness, and the wire size.

Step3: Check the power switch is in OFF position, and then plug the power cord into its electrical outlet.

Step4: While holding the Torch with the wire and tip clearly out of the way of any grounded objects, turn the power switch to ON position.

Step5: Orient yourself on the area to be welded, and then place the Face Shield over your eyes.

Warning: Never look at the ignited arc without ANSI approved, arc shaded, eye protection in a full-face shield. Permanent eye damage or blindness can occur. Skin burns can occur. Never breathe arc fumes.

Step6: Press (and hold) the torch button and stroke the area to be welded with the electrode wire to ignite the arc.

Step7: Once the arc is ignited, tilt the electrode wire forward at an angle of approximately 35° (as diagram 3-3).

Step8: When the weld is complete, loose the torch button and lift the wire clearly away form any grounded object, set the Face Shield down and turn the Power Switch to the "OFF" position.

Step9: Unplug the Power Cord from the electrical outlet.

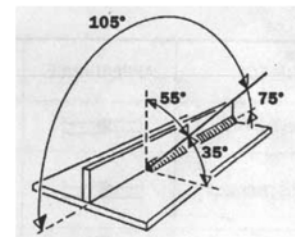

Diagram 3-3

3.3.2 Use mild steel wire

The welder can use with mild steel wire and shield gas for welding carbon steel. The shielding gas should be either pure (100%) CO₂ or a 75% argon-25% CO₂ mixture.

Make sure you use proper welding polarity: as diagram 3-2A, grounding cable connect "-" terminal, another cable (welding torch cable) connect "+" terminal. The diameter of the wire you select should correspond to the thickness of the work piece. Make sure that the contact tip is match the size of the wire diameter.

Step1: Connect work clamp onto metal to be welded, or to the metal workbench where the object is mounted and electrically connected.

Step2: Before plugging in, adjust amperage and wire feed speed according to material type and thickness, and the wire size.

Step3: Open the gas valve of regulator; press (and hold) the torch trigger set a flow of 5-7 L/Min (depending on the welding position chosen).

Step4: Check the power switch is in OFF position, and then plug the power cord into its electrical outlet.

Step5: While holding the Torch with the wire and tip clearly out of the way of any grounded objects, turn the power switch to ON position.

Step6: Orient yourself on the area to be welded, and then place the Face Shield over your eyes.

Warning: Never look at the ignited arc without ANSI approved, arc shaded, eye protection in a full-face shield. Permanent eye damage or blindness can occur. Skin burns can occur. Never breathe arc fumes.

Step7: Press (and hold) the torch trigger and stroke the area to be welded with the electrode wire to ignite the arc.

Step8: Once the arc is ignited, tilt the electrode wire forward at an angle of approximately 35° (as diagram 3-3).

Step9: When the weld is complete, loose the torch button and lift the wire clearly away form any grounded object, set the Face Shield down and turn the Power Switch to the “OFF” position.

Step10: Unplug the Power Cord from the electrical outlet.

Step11: Close the gas cylinder valve.

Step12: Depress torch trigger to release gas in regulator, gas pressure indicator will return to 0.



Cautions

If welding with large current for a long time and exceed the duty cycle, the overload lamp will light, and the welder will turn off until it cools down. If this happens, you must stop welding and wait about 10 minutes, then you can continue.

3.4 Basic Welding Technique

Setting of the Power Supply

The setting of the Mig 210 requires some practice by the operator, the welding Power Supply having two control settings that have to balance. These are the Wire Speed control and the Voltage Control switches. The welding current is determined by the Wire Speed control, the current will increase with increased Wire Speed, resulting in a shorter arc. Less wire speed will reduce the current and lengthen the arc. Increasing the welding voltage hardly alters the welding current level, but lengthens the arc. By decreasing the voltage, a shorter arc is obtained with little change in welding current.

When changing to a different electrode wire diameter, different control settings are required. A thinner electrode wire needs more Wire Speed to achieve the same current level.

A satisfactory weld cannot be obtained if the wire speed and voltage switch settings are not adjusted to suit the electrode wire diameter and dimensions of the work piece.

If the Wire Speed is too high for the welding voltage, “stubbing” will occur as the wire dips into the molten pool and does not melt. Welding in these conditions normally produces a poor weld due to lack of fusion. If, however, the welding voltage is too high, large drops will form on the end of the electrode wire, causing spatter. The correct setting of voltage and Wire Speed can be seen in the shape of the weld deposit and heard by a smooth regular arc sound.

Travel Speed

Speed at which a weld travels influences the width of the weld and penetration of the welding run.

Position of MIG gun

The angle of MIG gun to the weld has an effect on the width of the weld run.

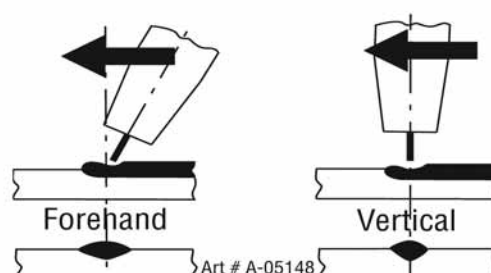

Figure 3-4 MIG Gun Angle

Distance from the MIG Gun Nozzle to the Work Piece

The electrode stick out from the MIG gun nozzle should be between 5/64" (2.0mm) to 13/64" (5.0mm). This distance may vary depending on the type of joint that is being welded.

Art # A-07186

Solid Wire

Flux Cored Wire

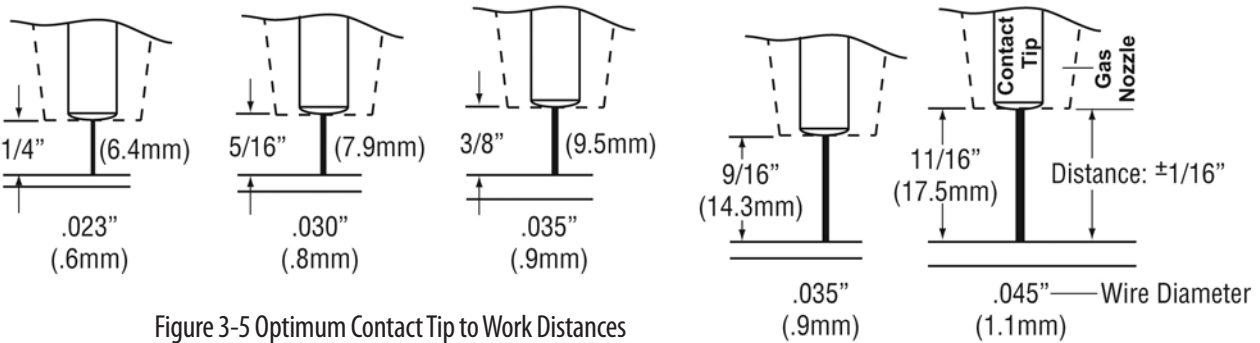

Figure 3-5 Optimum Contact Tip to Work Distances

Electrode Wire Size Selection

The choice of electrode wire size in conjunction with shielding gas used depends on:

- Thickness of the metal to be welded,
- Type of joint,
- Capacity of the wire feed unit and power supply,
- The amount of penetration required,
- The deposition rate required,
- The bead profile desired,
- The position of welding and
- Cost of the electrode wire.

Advantages of MIG welding forehand:

- Allows superior visibility of the weld zone
- Flatter weld bead
- Shallower penetration

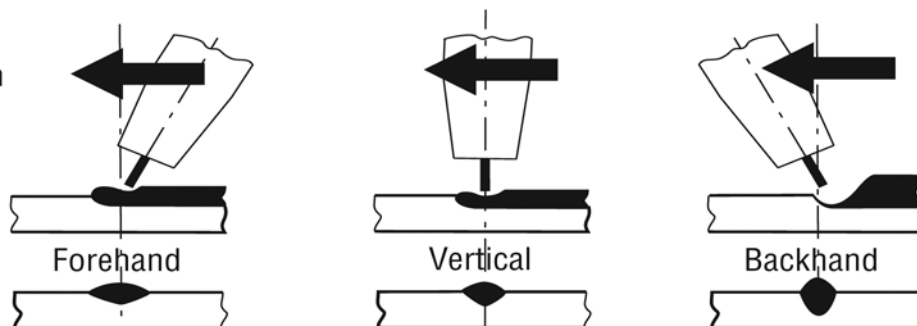

Art # A-07185

Figure 3-6 MIG Gun Angle

3.5 Technical Tips

Reduce Porosity in the Weld Metal

- Weld in still air to ensure gas coverage
- Clean the dirty, oil, paint, oxidization or grease from the metal to be welded
- Eliminate any gas leaks in the hose
- Make sure the gas cylinder is not empty with a flow rate of about 25cfh

Electrode Wire Burns Back to the Contact Tip

- Wire feed speed is too low
- MIG gun liner is blocked with dust or metallic dust
- Bent MIG gun liner
- Damage or worn inlet or outlet wire guides in the wire drive system

Irregular Weld Beard Shape

- Incorrect or worn feed roller size
- Incorrect size or worn contact tip
- Bad work lead contact to work piece

No Strength in the Weld Joint

- Wire feed speed (welding current) is too low
- Incorrect gas for the material being welded
- Joint preparation too narrow or gap too tight

Cracks Develop in the Weld Metal

- Arc voltage is too high
- The weld cooling rate is too fast
- The stresses in the welded metal are too high
- Weld penetration is too narrow and deep

4.1 Basic Troubleshooting

The basic level of troubleshooting is that which can be performed without special equipment or knowledge, and without removing the covers from the Power Supply.

If major components are faulty, then the Power Supply should be returned to an Accredited Thermal Arc Service Agent for repair.

4.2 Solving Problems Beyond the Welding Terminals

The general approach to fix Gas Metal Arc Welding (GMAW) problems is to start at the wire spool then work through to the MIG torch. There are two main areas where problems occur with GMAW:

1. Porosity

When there is a gas problem the result is usually porosity within the weld metal. Porosity always stems from some contaminant within the molten weld pool which is in the process of escaping during solidification of the molten metal.

Contaminants range from no gas around the welding arc to dirt on the work piece surface. Porosity can be reduced by checking the following points:

1. *Gas cylinder contents and flow meter.*
 - a. Ensure that the gas cylinder is not empty and the flow meter is correctly adjusted to 20-25CFM (15 litres per minute).
2. *Gas leaks*
 - a. Check for gas leaks between the regulator/cylinder connection and in the gas hose to the Power Source.
3. *Internal gas hose in the Power Source.*
 - a. Ensure the hose from the solenoid valve to the MIG torch adaptor has not fractured and that it is connected to the MIG torch adaptor.
4. *Welding in a windy environment.*
 - a. Shield the weld area from the wind or increase the gas flow.
5. *Welding dirty, oily, painted, oxidized or greasy plate.*
 - a. Clean contaminates off the plate

6. *Distance between the MIG torch nozzle and the work piece.*
 - a. Keep the distance between the MIG torch nozzle and the work piece to a minimum.
7. *Maintain the MIG torch in good working order.*
 - a. Ensure that the gas holes are not blocked and gas is exiting out of the torch nozzle. Refer to WARNING below
 - b. Do not restrict gas flow by allowing spatter to build up inside the MIG torch nozzle.
 - c. Check that the MIG gun O-rings are not damaged.

**WARNING**

Disengage the drive roll when testing for gas flow by ear.

2. Inconsistent wire feed

Wire feeding problems can be reduced by checking the following points:

1. *Wire spool brake is too tight.*
 - a. Feed roller driven by motor in the cabinet will slip.
2. *Wire spool brake is too loose.*
 - a. Wire spool can unwind and tangle.
3. *Worn or incorrect feed roll size.*
 - a. Use 'U' groove feed roll matched to the aluminum wire size you are welding. Use 'V' groove feed roll matched to the steel wire size you are welding. Use 'knurled V' groove feed roll matched to the flux cored wire size you are welding.
4. *Misalignment of inlet/outlet guides.*
 - a. Wire will rub against the misaligned guides and reduces wire feedability.
5. *Liner blocked with swarf.*
 - a. Slag is produced by the wire passing through the feed roll, if excessive pressure is applied to the pressure adjustment device. Slag can also be produced by the wire passing through an incorrect feed roll groove shape or size. Slag is fed into the conduit where it accumulates thus reducing wire feedability.

6. *Incorrect or worn contact tip.*

- a. The contact tip transfers the weld current to the electrode wire. If the hole in the contact tip is too large then arcing may occur inside the contact tip resulting in the electrode wire jamming in the contact tip. When using soft electrode wire such as aluminum it may become jammed in the contact tip due to expansion of the wire when heated. A contact tip designed for soft electrode wires should be used.

7. *Poor work lead contact to work piece.*

- a. If the work lead has a poor electrical contact to the work piece then the connection point will heat up and result in a reduction of power at the arc.

8. *Bent conduit.*

- a. This will cause friction between the wire and the conduit thus reducing wire feedability.

4.3 Solving Welding Problems

FAULT	CAUSE	REMEDY
A. Undercut.	1. Welding arc voltage too high.	Reduce voltage by reducing the output voltage control switch position or increase the wire speed.
	2. Incorrect torch angle	Adjust angle
	3. Excessive heat input	Increase the torch travel speed and/or reduce welding current by reducing the output voltage control switch position or reducing the wire speed.
	4. Weld speed too fast	Reduce weld speed.
B. Lack of penetration.	1. Welding current too low	Increase welding current by increasing wire speed and increasing voltage selection switch position.
	2. Joint preparation too narrow or gap too tight	Increase joint angle or gap
	3. Shielding gas incorrect	Change to a gas which gives higher penetration
	4. Weld speed too fast	Reduce weld speed.
C. Lack of fusion.	1. Voltage too low	Increase voltage by increasing output voltage control switch position.
	2. Weld speed too fast	Reduce weld speed.
D. Excessive spatter.	1. Voltage too high	Lower voltage by reducing the voltage selection switch or increase wire speed control.
	2. Voltage too low	Raise voltage by increasing the output voltage control switch or reduce wire speed control.
	3. Weld speed too fast	Reduce weld speed.
E. Irregular weld shape.	1. Incorrect voltage and current settings. Convex, voltage too low. Concave, voltage too high.	Adjust voltage and current by adjusting the voltage selection switch and the wire speed control.
	2. Wire is wandering	Replace contact tip
	3. Incorrect shielding gas	Check shielding gas.
	4. Insufficient or excessive heat input	Adjust the wire speed control or the output voltage control switch.
	5. Weld speed too fast	Reduce weld speed.
A. Weld cracking	1. Weld beads are too small	Decrease travel speed
	2. Weld penetration narrow and deep	Reduce current and voltage and increase Mig torch travel speed or select a lower penetration shielding gas.
	3. Excessive weld stresses	Increase weld metal strength or revise design
	4. Excessive voltage	Decrease voltage by reducing the voltage selection switch.
	5. Cooling rate too fast	Slow the cooling rate by preheating part to be welded or cool slowly.
	6. Weld speed too fast	Reduce weld speed.
B. Cold weld puddle.	1. Faulty rectifier unit	Have an Accredited Thermal Arc Service Agent to test then replace the faulty component.
	2. Loose welding cable connection.	Check all welding cable connections.
	3. Low Primary Voltage	Contact supply authority
	4. Weld speed too fast	Reduce weld speed.
C. Arc does not have a crisp sound that short arc exhibits when the wirefeed speed and voltage are adjusted correctly.	1. The MIG torch has been connected to the wrong voltage polarity on the front panel.	Connect the MIG torch to the positive (+) welding terminal for solid wires and gas shielded flux cored wires. Refer to the electrode wire manufacturer for the correct polarity.
	2. Weld speed too fast	Reduce weld speed.

**Warning**

Be **CERTAIN** to shut off the welder, disconnect it from power, and discharge the torch to ground before adjusting, cleansing, or repairing the unit.

Electrical repairs should only be made by trained technician.

TROUBLESHOOTING

Symptom	Possible Cause	Corrective Action
No output	<ol style="list-style-type: none"> 1. Duty cycle exceeded 2. Poor work clamp connection 3. Blown breaker or fuse 	<ol style="list-style-type: none"> 1. Allow welder to cool until lamp goes out 2. Be sure all connections are secure, and attaching surface is clean 3. Reduce circuit load, reset breaker or replace fuse
Wire tangles at drive roller	<ol style="list-style-type: none"> 1. Wrong size contact tip 2. Torch liner clogged or damaged 3. Contact tip clogged or damaged 4. Drive roller worn 5. Not enough tension 	<ol style="list-style-type: none"> 1. Use proper size contact tip 2. Clean or replace wire liner 3. Clean or replace contact tip 4. Replace drive roller 5. Tighten tension knob
Gun nozzle arcs to work surface	<ol style="list-style-type: none"> 1. Slag inside gun nozzle 2. Insulation ring melted or expired 	<ol style="list-style-type: none"> 1. Clean slag from gun nozzle 2. Replace nozzle
Work clamp and/or cable gets hot	<ol style="list-style-type: none"> 1. Poor contact 2. Using an extension cord with excessive length 	<ol style="list-style-type: none"> 1. Be sure all connections are secure, and attaching surface is clean 2. Never use an extension cord longer than 20 ft
Wire does not feed	<ol style="list-style-type: none"> 1. Wire jammed 2. Out of wire 3. Not enough tension 4. Wire liner worn 5. Contact tip clogged 	<ol style="list-style-type: none"> 1. Reload wire 2. Replace wire spool 3. Tighten tension knob if wire is slipping 4. Replace liner 5. Replace contact tip
Weld pops and sputters	<ol style="list-style-type: none"> 1. Wire speed setting 2. Contact tip size too large 3. Polarity set incorrectly 4. Drive roller slipping 5. Gas bottle empty 	<ol style="list-style-type: none"> 1. Tune in correct setting 2. Replace contact tip 3. Reverse polarity 4. Increase tension 5. Replace gas bottle

5.1 Maintenance



Warning

Before performing any maintenance on the Welder, unplug the Power Cord from the electrical out let and allow all parts of the welder to cool thoroughly.

1. Periodically open the Access Panel from the unit and, using compressed air, blow out all dust and debris from the interior. Inspect all air vents and cooling slots to ensure that they are clean and unobstructed.
2. Always store the Welder in a clean, dry, safe location out of reach of children and other unauthorized people.
3. For optimal weld quality, clean and inspect the Contact Tip and Nozzle before each use, as follows:

NOZZLE INSPECTION, CLEANING, AND REPLACEMENT

1. Turn the Nozzle counterclockwise while pulling to remove.
2. Scrub the interior of the Nozzle clean with a wire brush.
3. Examine the end of the Nozzle. The end should be flat and even. If the end is uneven, chipped, melted, cracked, or otherwise damaged, the Nozzle will adversely effect the weld and should be replaced.
4. Reinstall the Nozzle after inspecting and cleaning the Contact Tip.

CONTACT TIP INSPECTION, CLEANING, AND REPLACEMENT

1. Make sure the entire Welding Torch is completely cool before proceeding.
2. Remove the Nozzle as explained above. Then remove the Contact Tip.
3. Scrub the exterior of the Contact Tip clean with a wire brush. Check that the Contact Tip is the proper type for the wire size used.
4. Examine the hole at the end of the Contact Tip for the following problems: The hole should be an even circle, and should not be oblong or have any bulges in it; The Contact Tip will decrease in efficiency as the center hole enlarges.
5. If any problems are noted with a Contact Tip, it is recommended to have it replaced.
6. When inspection and maintenance is completed, reinstall the Contact Tip and Nozzle.

6.1 Assembly Drawing

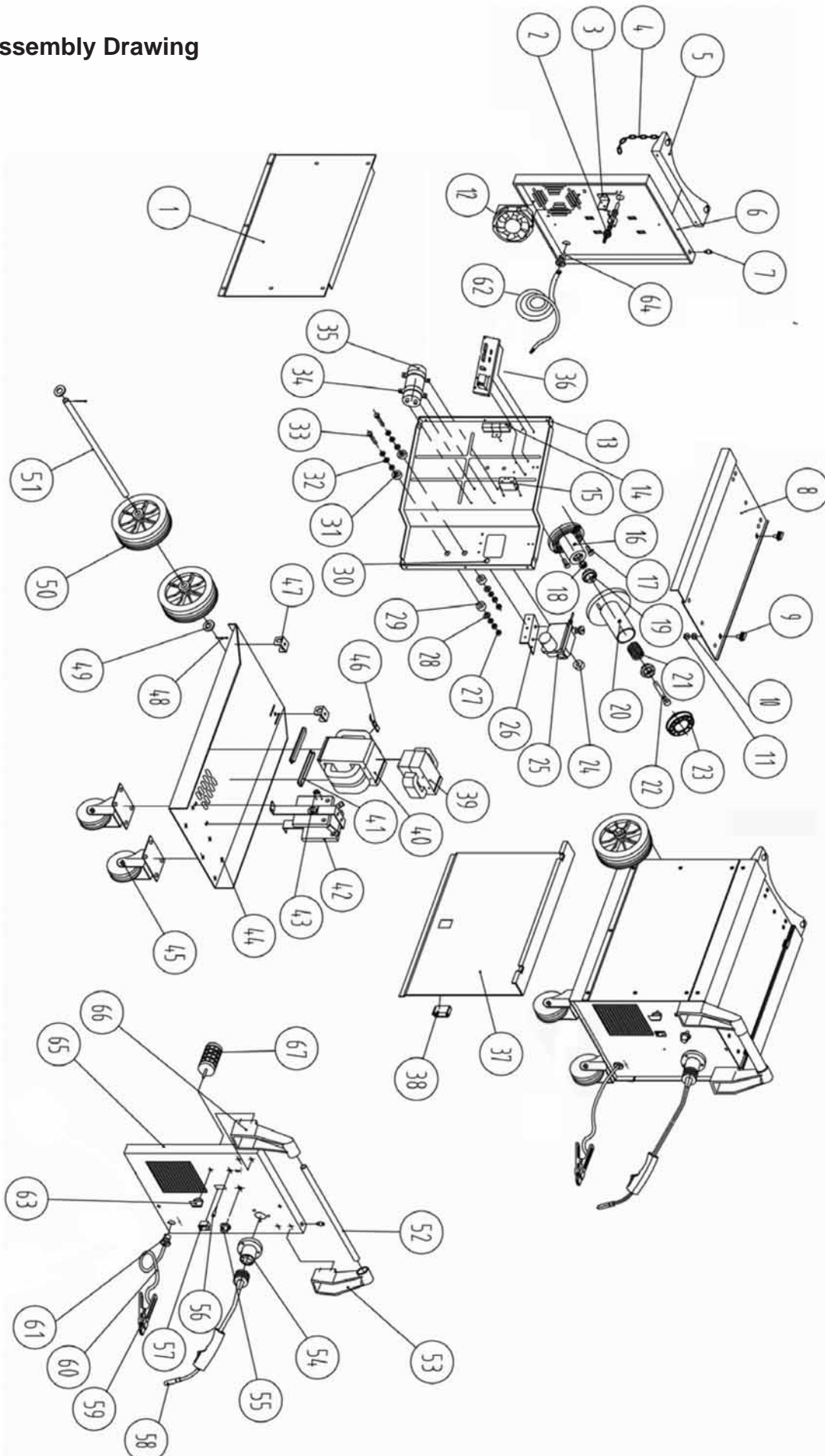

7.1 Parts List

Item #	Description	Item #	Description
1	Side Panel	35	Capacitance
2	Solenoid Valve	36	Circuit Board
3	Solenoid Valve Bracket	37	Access Panel
4	Chain	38	Latch
5	Gas Bottle Support	39	Filter Reactor
6	Back Panel	40	Main Transformer
7	Rubber Support	41	Transformer Carriage
8	Top Panel	42	Rectifier Rack
9	Hinge	43	Thermal Switch
10	Rubber Washer	44	Bottom Panel
11	Nut, M8	45	Caster
12	Fan	46	Thermal Switch
13	Inner Panel	47	Axes Bracket
14	Resistance	48	Cotter Pin
15	Relay	49	Washer, 20
16	Wire disc seat	50	Wheel
17	Bolt, M8x25	51	Axle
18	Nut, M10	52	Handle
19	Plastic Knob	53	Right Handle Socket
20	Spool Holder B	54	Torch Seat
21	Spring	55	Wire Speed Control Knob
22	Bolt, M10x80	56	Overload Indicator Light
23	Retainer	57	ON/OFF Switch
24	Wire Feed Wheel	58	*Welding Torch
25	Wire Feeder	59	Ground Clamp
26	Wire Feeder Support	60	Ground Cable
27	Copper Nut, M8	61	Cable Tip, PG13.5
28	Washer, 8	62	Line Cable
29	Insulating Washer	63	Voltage Control Knob
30	Rubber Ring	64	Cable Tip, PG16
31	Insulating Washer	65	Front Panel
32	Washer, 8	66	Left Handle Socket
33	Copper Bolt, M8x55	67	Voltage Control Switch
34	Capacitor Installing Clamp	68	

*Welding Torch is according to the customer's requirements.

7.2 Pack List

No.	Name	Specification	Qty	Remark
1	Welding power		1	
2	Operating manual		1	
3	Welding wire	0.6*1Kg	1	
4	Handle socket		2	
5	Earth clamp		1	
6	Wheel	8"	2	
7	Caster		2	
8	Axle bracket		2	
9	Axle	Φ20	1	
10	Straight handle		1	
11	Contact tip	Φ0.8	1	
12	Bolt	GB818 M4×10	2	
13	Cotter pin	GB91 3.2×40	2	
14	Washer	GB97.1 20	2	
15	Chain		1	
16	*Welding Torch		1	

weldtech



Congratulations on your new Weldtech product. We are proud to have you as our customer and will strive to provide you with the best service and reliability in the industry. This product is backed by our extensive warranty and world-wide service network. To locate your nearest distributor or service agency call **0800 387 678**, or email us at **info@euroquip.co.nz**.