



GT8000ESi ELECTRIC START INVERTER GENERATOR

8000W



Please ensure that you read this manual in full before using your machine and follow the maintenance and operation instructions carefully.

OPERATING INSTRUCTIONS

Contents

Introduction	3
Environmental Protection.....	3
Scope of Product.....	3
Description of Symbols.....	3
Specifications.....	3
Operator Safety	4
Safety Rules.....	4
Symbols.....	7
Safety Labels.....	8
Generator Capacity	9
Power Management.....	9
Wattage Reference Guide.....	9
Unpacking	10
Unpacking the Generator.....	10
Box Contents.....	10
Features and Controls	11
Generator.....	11
Control Panel.....	12
Know Your Generator	13
Assembly	15
Connecting the Battery.....	15
Checking/Adding Engine Oil.....	16
Using Fuel Stabilizer.....	16
Checking/Adding Fuel.....	17
Operation	17
Starting the Engine.....	17
Stopping the Engine.....	18
AC Applications.....	19
Parallel Operation (optional).....	19
Standby Power.....	20
High Altitude Operation.....	20
Maintenance	20
General Maintenance.....	20
Checking / Cleaning Air Filter.....	20
Changing Engine Oil.....	21
Spark Plug Replacement.....	22
Spark Arrester Service.....	23
Draining Fuel Tank / Carburetor.....	23
Transporting.....	23
Maintenance Schedule.....	24
Storage	25
Troubleshooting	26
Parts	27
Parts List.....	28
Warranty	29
Notes	30

Introduction

Your new GT Power Generator will more than satisfy your expectations. It has been manufactured under stringent quality standards to meet superior performance criteria. You will find your new tool easy and safe to operate, and with proper care, it will give you many years of dependable service.

Carefully read through this entire Instruction Manual before using your new Generator. Take special care to heed the cautions and warnings.

Your generator has many features that will make your job faster and easier. Safety, performance, and dependability have been given top priority in the development of this tool, making it easy to maintain and operate.

Environmental Protection

Recycle unwanted materials instead of disposing of them as waste. All tools, hoses and packaging should be sorted, taken to the local recycling centre and disposed of in an environmentally safe way.



Scope Of Product

This product is suited for home, camping and emergency power applications. It will operate most powertools, appliances and lighting.

Description Of Symbols

The rating plate on your tool may show symbols. These represent important information about the product or instructions on its use.



Wear hearing protection.
Wear eye protection.
Wear breathing protection.



Conforms to relevant standards for electromagnetic compatibility.

Specifications

AC Output:	230V AC ~ 50Hz
Rated Power:	7000W
Peak Power:	8000W
Phase:	Single
Displacement:	459cc
Engine:	16HP, 4 stroke OHV
No Load Speed:	3000 RPM
Fuel Tank Capacity:	26L
Fuel Type:	Unleaded petrol
Oil Type:	SAE30 4 Stroke
Oil Capacity:	1.1L
Noise Level:	59dBA
Net Weight:	105kg
Run Time:	10hrs @ 50% load
Power Outlet:	2
Starting System:	Electric/Recoil
Dimensions:	790 x 660 x 810

Operator Safety

DANGER:

Carbon Monoxide. Using a generator indoors **CAN KILL YOU IN MINUTES.**

Generator exhaust contains high levels of carbon monoxide (CO), a poisonous gas you cannot see or smell. If you can smell the generator exhaust, you are breathing CO. But even if you cannot smell the exhaust, you could be breathing CO.

- Never use a generator inside homes, garages, crawlspaces, or other partly enclosed areas. Deadly levels of carbon monoxide can build up in these areas. Using a fan or opening windows and doors does NOT supply enough fresh air.
- ONLY use a generator outdoors and far away from open windows, doors, and vents. These openings can pull in generator exhaust.

Even when you use a generator correctly, CO may leak into the home. ALWAYS use a battery-powered or battery-backup CO alarm in the home.

If you start to feel sick, dizzy, or weak after the generator has been running, move to fresh air RIGHT AWAY. See a doctor. You could have carbon monoxide poisoning.

WARNING:

Read and understand all instructions. Failure to follow all instructions listed below could result in electrocution, fire, and/or carbon monoxide poisoning, which can cause death or serious injury.

WARNING:

National Electric Code requires generator to be grounded to an approved earth ground. Before using the ground terminal, consult a qualified electrician, electrical inspector, or local agency having jurisdiction for local codes or ordinances that apply to the intended use of the generator.

Safety Rules

This manual contains important instructions for this product that should be followed during installation and maintenance of the generator.

- Do not connect to a building's electrical system unless the generator and transfer switch have been properly installed and the electrical output has been verified by a qualified electrician. The connection must isolate the generator power from utility power and must comply with all applicable laws and electrical codes.
- Do not allow children or untrained individuals to use this unit.
- Do not start or operate the engine in a confined space, building, near open windows, or in other unventilated space where dangerous carbon monoxide fumes can collect. Carbon monoxide, a colorless, odorless, and extremely dangerous gas, can cause unconsciousness or death.
- Keep all bystanders, children, and pets at least 10 feet away.

- Wear sturdy and dry shoes or boots. Do not operate while barefoot.
- Do not operate generator when you are tired or under the influence of drugs, alcohol, or medication.
- Keep all parts of your body away from any moving parts and all hot surfaces of the unit.
- Do not touch bare wire or receptacles.
- Do not use generator with electrical cords which are worn, frayed, bare, or otherwise damaged.
- Before storing, allow the engine to cool and drain fuel from the unit.
- Do not operate or store the generator in rain, snow, or wet weather.
- Store the generator in a well-ventilated area with the fuel tank empty. Fuel should not be stored near the generator.
- Empty fuel tank, turn the engine/choke lever to the off position and restrain the unit from moving before transporting in a vehicle.
- Allow engine to cool for five minutes before refueling.
- To reduce the risk of fire and burn injury, handle fuel with care. It is highly flammable.
- Do not smoke while handling fuel.
- Store fuel in a container approved for gasoline.
- Position the unit on level ground, stop engine, and allow to cool before refueling.
- Wipe spilled fuel from the unit.
- Loosen fuel cap slowly to release pressure and to keep fuel from escaping around the cap.
- Tighten the fuel cap securely after refueling.
- Never attempt to burn off spilled fuel under any circumstances.
- Generators vibrate in normal use. During and after the use of the generator, inspect the generator as well as extension cords and power supply cords connected to it for damage resulting from vibration. Have damaged items repaired or replaced as necessary. Do not use plugs or cords that show signs of damage such as broken or cracked insulation or damaged blades.
- For power outages, permanently installed stationary generators are better suited for providing back-up power to the home. Even a properly connected portable generator can become overloaded. This may result in overheating or stressing the generator components, possibly leading to generator failure.
- Use only authorized replacement parts and accessories and follow instructions in the Maintenance section of this manual. Use of unauthorized parts or failure to follow maintenance instructions may create a risk of shock or injury.
- Maintain the unit per maintenance instructions in this Operator's Manual.
- Inspect the unit before each use for loose fasteners, fuel leaks, etc. Replace damaged parts.

**WARNING:**



When this generator is used to supply a building wiring system: generator must be installed by a qualified electrician and connected to a transfer switch as a separately derived system. The generator shall be connected through a transfer switch that switches all conductors other than the equipment grounding conductor. The frame of the generator shall be connected to an approved grounding electrode. Failure to isolate the generator from power utility can result in death or injury to electric utility workers.

- Do not use this generator to provide power for emergency medical equipment or life support devices.
- Exhaust contains poisonous carbon monoxide, a colorless, odorless gas. Breathing exhaust can cause loss of consciousness and can lead to death. If running in a confined or partially-enclosed area, the air may contain a dangerous amount of carbon monoxide. To keep exhaust fumes from building up, always provide adequate ventilation.
- Always use a battery-powered carbon monoxide detector when running the generator. If you begin to feel sick, dizzy, or weak while using the generator, shut it off and get to fresh air immediately. See a doctor. You may have carbon monoxide poisoning.
- Place the generator on a flat, stable surface with a slope of no more than 4°.
- Operate outdoors in a well-ventilated, well-lit area isolated from working areas to avoid noise interference.
- Operate outdoors in a well-ventilated, well-lit area isolated from working areas to avoid noise interference.
- Operating the generator in wet conditions could result in electrocution. Keep the unit dry.
- Keep the generator a minimum of one metre away from all types of combustible material.
- Do not operate generator near hazardous material.
- Do not operate generator at a gas or natural gas filling station.
- Do not touch the muffler or cylinder during or immediately after use; they are HOT and will cause burn injury.
- This generator has a neutral floating condition. This means the neutral conductor is not electrically connected to the frame of the machine.
- Do not allow the generator's gas tank to overflow when filling. Fill to 25mm below the top neck of the gasoline tank to allow for fuel expansion. Do not cover the fuel tank cap when the engine is running. Covering the fuel tank cap during use may cause engine failure and/or damage to the tool.

- Do not smoke when filling the generator with gasoline.
- Shut down the engine and allow to cool completely before adding gasoline or lubricant to the generator.
- Do not remove the oil dipstick or the fuel tank cap when the engine is running.
- Pay close attention to all safety labels located on the generator.
- Keep children a minimum of 3 metres away from the generator at all times.
- The unit operates best in temperatures between -5°C and 40°C with a relative humidity of 90% or less.
- For outdoor use only.
- Save these instructions. Refer to them frequently and use them to instruct others who may use this product. If you loan someone this product, loan them these instructions also.

Symbols

The following signal words and meanings are intended to explain the levels of risk associated with this product.

SYMBOL	SIGNAL	MEANING
	DANGER:	Indicates an imminently hazardous situation, which, if not avoided, will result in death or serious injury.
	WARNING:	Indicates a potentially hazardous situation, which, if not avoided, could result in death or serious injury.
	CAUTION:	Indicates a potentially hazardous situation, which, if not avoided, may result in minor or moderate injury.
	NOTICE:	(Without Safety Alert Symbol) Indicates important information not related to an injury hazard, such as a situation that may result in property damage.

Safety Labels

The information below can be found on the generator. For your safety, please study and understand all of the labels before starting the generator.

<p>⚠ DANGER</p> <p>Using a generator indoors can kill you in minutes. Generator exhaust contains carbon monoxide. This is a poison you cannot see or smell.</p> <p>Never use inside a home or garage, even if doors and windows are open.</p> <p>Only use outside and far away from windows, doors and vents.</p>				<p>⚠ WARNING!</p> <p> Read operator's instructions before use.</p> <p> Fuel is flammable. Allow engine to cool 2 minutes before refilling.</p> <p> Engine emits toxic carbon monoxide. DO NOT operate generator in enclosed area.</p> <p> DO NOT operate generator in wet weather, or in wet conditions.</p>					

LEFT MAINTENANCE COVER
For engine oil inspection/replacement

TO OPEN:

1. Unscrew the 4 bolts with the sleeve
2. Take out the cover.

SAE 10W-30
CAPACITY: 1.1L

Add engine oil to full mark to start. Engine will not start or will shut off if sensor detects low oil level.

CHECK ENGINE OIL

RIGHT MAINTENANCE COVER

For: - Air filter inspection/cleaning
- Spark plug inspection/replacement
- Battery inspection/replacement

TO OPEN:

1. Unscrew the bolts with the sleeve.
2. Take out the cover.

MAINTENANCE COVER FOR BATTERY

NOTICE

Use the specified spark plug only.
Specified plug: NGK BPR6S

⚠ WARNING!

DO NOT TOUCH HOT SURFACES

This generator produces extreme heat. Severe burning may occur if in contact with skin.

Generator Capacity

Power Management

Use the following formula to convert voltage and amperage to watts:

$$\text{Volts} \times \text{Amps} = \text{Watts}$$

To prolong the life of your generator and attached devices, follow these steps to add electrical load:

1. Start the generator with no electrical load attached.

2. Allow the engine to run for several minutes to stabilize.

3. Plug in and turn on the first item. Attach the item with the largest load first.

4. Allow the engine to stabilize.

5. Plug in and turn on the next item.

6. Allow the engine to stabilize.

7. Repeat steps 5-6 for each additional appliance or tool.

Wattage Reference Guide

Appliances	Approx Run (W)	Approx Start (W)	Appliances	Approx Run (W)	Approx Start (W)
Microwave 750W	750	1200	Central Air Conditioner:		
Coffee Maker	1750	1750	10,000 BTU	1500	2200
Electric Clothes Drier	5750	5750	24,000 BTU	3800	5000
Washing Machine	1150	2300	32,000 BTU	5000	6500
Refrigerator	700	2200	Room Air Conditioner		
Lights	100	100	10,000 BTU	1500	2200
Colour Television	350	350	Circular Saw 7 1/4"	1400	2300
Electric Frypan	1500	1500	Chainsaw 2HP	1100	2500
Dehumidifier	400	400	Portable Air Compressor	1200	3600
Computer - Desktop	700	700	Hand Drill 1/2"	600	900
VCR	50	50	Drill 1/2"	600	900
Dishwasher - Cool Dry	700	1400	Battery Charger - 15 amp	500	700
- Hot Dry	1450	2000	Electric Welder - 200 amp AC	9000	9000
Toaster - 2 Slice	1250	1250	Jigsaw	300	400
- 4 Slice	1600	1600	Electric Weed Trimmer	500	650
Freezer	2200	2500	Router	1000	1300
Hair Dryer	800-1700	800-1700	Belt Sander	1000	1300
Steam Iron	1800	1800	Table Saw 10"	1750	4250
Garage Door Opener - 1/4 HP	550	1100	Bench Grinder	1400	2450
- 1/3 HP	725	1400	Concrete Mixer 3.5c/f	1900	2500
Radio	200	200	Band Saw	1100	1350
Blender	375	500	Power Drill - Medium	1000	1200
Sump Pump 1/2 HP	1050	2150	- Heavy Duty	1500	1800
Well Pump 1/2 HP	1000	2100	Angle Grinder - 100mm	1000	1200
Household Water Pump	1200	2700	- 230mm	2400	2700

This chart lists average power requirements. Your particular tool or appliance may require more or less than the listed wattage. For exact wattages, check the data plate or owner's manual on the item you wish to power. Where START wattage is the same as RUN wattage, this signifies no additional power is required for starting.

**Total Running Watts + Highest Starting Watts
= Generator Power Needs**

Unpacking

Unpacking the Generator

 **WARNING:**

Always have assistance when lifting the generator. The generator is heavy; lifting it could cause bodily harm. Avoid cutting on or near staples to prevent personal injury.

1. Carefully cut packing tape on top of carton.
2. Fold back top flaps to reveal instruction manual on top of the upper packing tray. Remove manual and save it for reference.
3. Remove contents from upper packing tray.
4. Remove and discard upper packing tray.
5. Unfold top of the plastic bag enclosing the generator.
6. Lift generator out of plastic bag and carton.
7. This machine has been shipped completely assembled. Make sure that all items listed in the box contents list are included.
8. Recycle or dispose of packaging materials properly.

 **WARNING:**

If any parts are damaged or missing do not operate this product until the parts are replaced. Use of this product with damaged or missing parts could result in serious personal injury.

 **WARNING:**

Do not use this product if any parts on the Packing List are already assembled to your product when you unpack it. Parts on this list are not assembled to the product by the manufacturer and require customer installation. Use of a product that may have been improperly assembled could result in serious personal injury.

- Inspect the product carefully to make sure no breakage or damage occurred during shipping.
- Do not discard the packing material until you have carefully inspected and satisfactorily operated the product.
- If any parts are damaged or missing, please call for assistance.

Box Contents

Check the contents against those listed below. If any parts are missing, please contact your local GT Power dealer.

Generator
 Battery Charging Cable (Optional)
 Engine Lubricant (Optional)
 Screwdriver
 Funnel
 Operator's Manual

 **WARNING:**

Do not attempt to operate the generator until assembly is complete. Failure to comply could result in possible serious personal injury.

⚠ WARNING:

Do not attempt to modify this product or create accessories not recommended for use with this product. Any such alteration or modification is misuse and could result in a hazardous condition leading to possible serious personal injury.

Features & Controls

Generator

1. Fuel Tank Cap
2. Handle
3. Right Maintenance Cover (for air filter/sparkplug /battery)
4. Wheel
5. Control Panel
6. Fuel Tank
7. Fuel Gauge
8. Left Maintenance Cover
9. Recoil Handle
10. Black Rubber Seal (Front)
11. Wheel Lock
12. Muffler

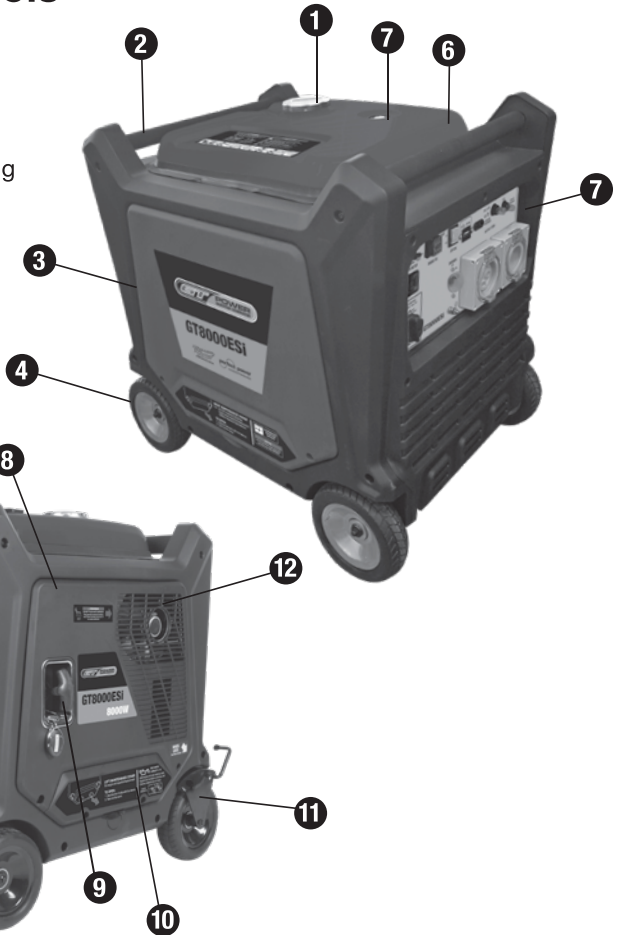

Control Panel

- | | |
|-------------------------------------|-------------------------------------|
| 1. Output Indicator | 11. 230V 15A Circuit Breaker Switch |
| 2. Overload Indicator | 12. AC 230V 15A Plug Socket |
| 3. Low Oil Indicator | 13. AC 230V 31A Plug Socket |
| 4. Main Switch | 14. 12V Circuit Breaker Switch |
| 5. USB Terminal | 15. ATS |
| 6. Engine Start | 16. Ground Terminal |
| 7. DC 12V 9A Plug Socket | 17. Two Wire Control Connector |
| 8. Low Idle | 18. Two Wire Control Switch |
| 9. Parallel Operation Outlets | 19. Fuel Switch |
| 10. 230V 31A Circuit Breaker Switch | 20. Hours |

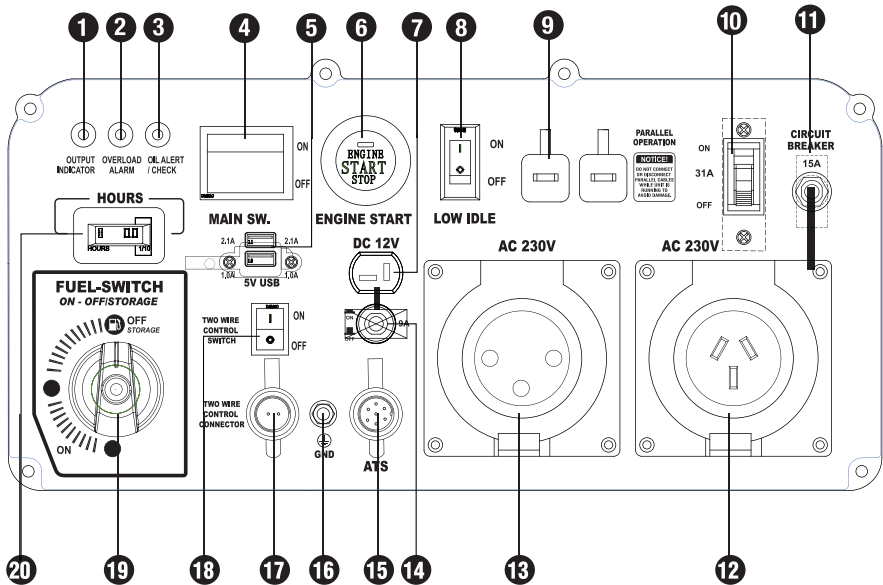

Know Your Generator

The safe use of this product requires an understanding of the information on the product and in this operator's manual as well as a knowledge of the project you are attempting. Before use of this product, familiarize yourself with all operating features and safety rules.

AC Receptacles

The receptacles can be used for operating appropriate appliances, electrical lighting, tools, and motor loads.

Air Filters

The air filters help to limit the amount of dirt and dust drawn into the unit during operation.

Eco Switch

The eco switch is used to control the speed of the engine and conserve fuel. When the switch is in the ON (I) position and no appliances are connected to the unit, the engine will idle. If an appliance is added, the engine speed will increase to power the item. If the appliance is removed, the engine will return to idle.

NOTICE:

If high electrical loads are connected simultaneously, turn the Eco switch to the OFF position to reduce voltage changes.

Handles

The generator is equipped with two handles for easy transport. Both handles should be used to move the generator.

Fuel Tank

To provide increased operating time, start with a full tank before operation. Always refuel with the engine OFF and cool.

Fuel Gauge

The fuel gauge is a mechanical device that measures the fuel level in the tank. The red indicator in the window will reference the level in relation to full or empty.

Ground Terminal

The ground terminal is used to assist in properly grounding the generator to help protect against electrical shock. Consult with a local electrician for grounding requirements in your area.

LED Display

LEDs provide feedback to indicate whether the generator is in use, overloaded, or in need of lubricant.

Oil Cap/Dipstick

Remove the oil fill cap to check and add lubricant to the generator when necessary.

Parallel Kit (Optional)

The non-polarized parallel kit terminals are used with a parallel kit (sold separately) that will allow generators to be linked together to increase output.

NOTE: Read and understand the parallel kit's instructions prior to use. Kit is for usage with this unit only.

Starter Grip

Used when the battery voltage is too low to turn the starter motor. Pulling the starter grip to manual start the generator's engine.

Maintenance Cover

Open and close the maintenance cover for maintenance of the generator.

Open the right maintenance cover for:

- Air filter inspection/cleaning
- Spark plug inspection/replacement
- Battery inspection/replacement

Open the left maintenance cover for:

- Engine oil inspection/replacement

DANGER:

Carbon Monoxide. Using a generator indoors **CAN KILL YOU IN MINUTES.**

Generator exhaust contains high levels of carbon monoxide (CO), a poisonous gas you cannot see or smell. If you can smell the generator exhaust, you are breathing CO. But even if you cannot smell the exhaust, you could be breathing CO.

- Never use a generator inside homes, garages, crawlspaces, or other partly enclosed areas. Deadly levels of carbon monoxide can build up in these areas. Using a fan or opening windows and doors does NOT supply enough fresh air.
- ONLY use a generator outdoors and far away from open windows, doors, and vents. These openings can pull in generator exhaust.

Even when you use a generator correctly, CO may leak into the home. ALWAYS use a battery-powered or battery-backup CO alarm in the home.

DANGER:

If you start to feel sick, dizzy, or weak after the generator has been running, move to fresh air **RIGHT AWAY**. See a doctor. You could have carbon monoxide poisoning.

WARNING:

Do not allow familiarity with this product to make you careless. Remember that a careless fraction of a second is sufficient to inflict serious injury.

DANGER:

Failure to properly ground generator can result in electrocution, especially if the generator is equipped with a wheel kit. Call an electrician for local grounding requirements.

GROUNDING THE GENERATOR

To reduce the risk of shock or electrocution, generator must be properly grounded. The nut and ground terminal on the frame must always be used to connect the generator to a suitable ground source. Connect the terminal of the ground wire between the lock washer and the nut, and tighten the nut fully. Connect the other end of the wire securely to a suitable ground source.

All electrical tools and appliances operated from this generator must be properly grounded by use of a third wire or be "Double Insulated."

Check and adhere to all applicable federal, state, and local regulations relating to grounding specifications. Consult a qualified electrician or service personnel if the grounding instructions are not completely understood or if in doubt as to whether the generator is properly grounded.

⚠ WARNING:

Do not use any attachments or accessories not recommended by the manufacturer of this product. The use of attachments or accessories not recommended can result in serious personal injury.

Assembly

Connecting the Battery

⚠ WARNING:

To reduce the risk of electrocution or explosion, do not short circuit the battery terminals or charge in a sealed container. Keep sparks and flame away.

⚠ WARNING:

Keep metal objects away from the battery terminals. Metal objects can make a connection from one terminal to another. Shorting the battery terminals together can cause sparks, burns, or a fire.

NOTICE:

The battery may require charging before the generator can be started using either the engine switch or the recoil starter. Once the generator is started, the battery will charge as the unit runs.

The battery cables must be connected before the generator can be operated.

To connect battery cables:

- Loosen the screws at the side of the right maintenance cover. Remove cover and set aside.

- Connect the red wires to the positive (+) terminal first, then connect the black wire to the negative (-) terminal. Make sure all connections are tight.
- Cover the terminals with the rubber covers.

NOTE: Be careful not to short across the terminals when installing. Shorting the terminals together can cause sparks, damage to the battery or generator, or even burns or explosions.

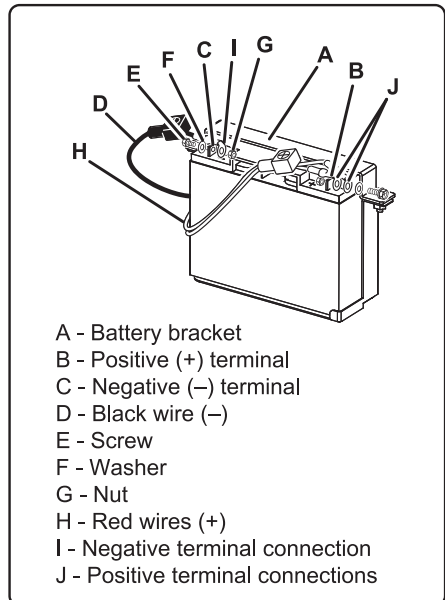
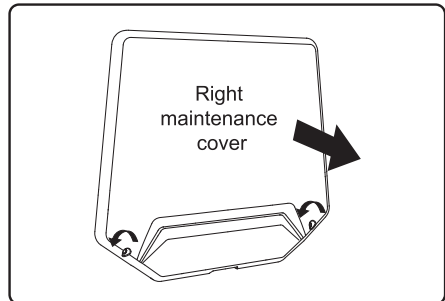

Checking / Adding Engine Oil

The generator is equipped with two handles for easy transport. Both handles should be used to move the generator.

NOTICE:

Attempting to start the engine before it has been properly filled with engine oil will result in equipment failure.

Engine oil has a major influence on engine performance and service life. For general, all-temperature use, SAE 10W-30 is recommended. Always use a 4-stroke engine oil that meets or exceeds the requirements.

NOTE: Non-detergent or 2-stroke engine oil will damage the engine and should not be used.

- Loosen the screws at the side of the left maintenance cover. Remove cover and set aside.
- Unscrew the oil cap/dipstick and remove.
- Wipe dipstick clean and re-seat in hole; do not re-thread.
- Remove dipstick again and check engine oil level. Engine oil level should fall between the minimum and maximum marks on the dipstick.
- If level is low, add engine oil.
- Replace and secure the cap/dipstick.

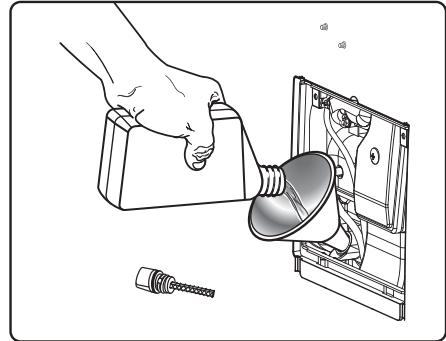
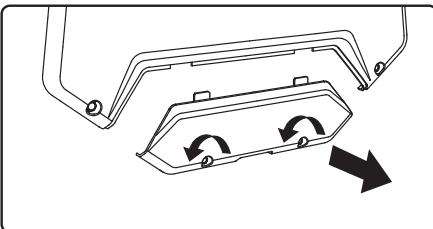

Using Fuel Stabilizer

Fuel gets old, oxidizes, and breaks down over time. Adding a fuel stabilizer (not included) extends the usable life of fuel and helps prevent deposits from forming that can clog the fuel system. Follow fuel stabilizer manufacturer's directions for correct ratio of stabilizer to fuel.

- Mix fuel stabilizer and petrol prior to filling the tank by using a gas can or other approved fuel container and shaking gently to combine.

NOTE: To control the amount of fuel stabilizer being added to the engine, always mix fuel stabilizer with petrol before fueling the tank rather than adding fuel stabilizer directly into the generator's fuel tank.

- Replace and secure fuel tank cap.
- Start and run the engine for at least 5 minutes to allow stabilizer to treat the entire fuel system.

Checking / Adding Fuel

WARNING:

Petrol and its vapors are highly flammable and explosive. To prevent serious personal injury and property damage, handle petrol with care. Keep away from ignition sources, handle outdoors only, do not smoke while adding fuel, and wipe up spills immediately.

When adding petrol to the generator, make sure the unit is sitting on a flat, level surface. If the engine is hot, let the generator cool before adding gas. ALWAYS fill the fuel tank outdoors with the machine turned off.

- Remove the fuel cap.
- Fill the fuel tank to 25mm below the top of the fuel neck.
- Replace and secure the fuel cap.

NOTE: Always use unleaded petrol with a pump octane rating of 91 or higher. Never use old, stale or contaminated petrol, and do not use an oil/gas mixture. Do not allow dirt or water into the fuel tank.

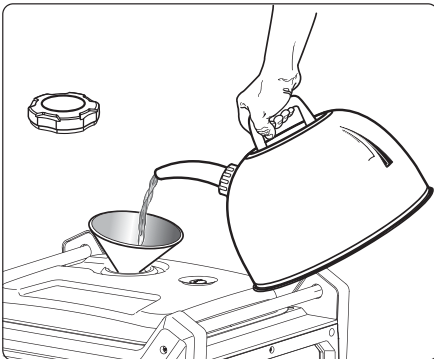

Operation

Starting the Engine

NOTICE:

On a level surface with the engine off, check the lubricant level before each use of the generator.

NOTE: If location of generator is not level, the unit may not start or may shut down during operation.

NOTICE:

Do not place the generator directly on the ground when using the unit in grassy areas or in areas with dense vegetation. Doing so could result in grass discoloration and/or localized soil damage.

- Unplug all loads from the generator.
- Set the Voltage Selector Switch (Optional) to match the voltage requirements for the application.
- Place the Eco Switch in the OFF position. (If you wish to use the Eco system, turn the Eco Switch to the ON position after the engine has warmed up for 2 or 3 minutes.)
- Turn the Multi-switch to the START position.
- **FOR ELECTRIC START:** Turn and hold the Engine Switch to the ON position.
- The Engine Switch functions for 5 seconds. As soon as the engine starts, the starter will stop automatically.
- If the engine fails to start, wait at least 10 seconds before operating the starter again.

FOR MANUAL START: Use the recoil starter when the battery voltage is too low to turn the starter motor.

- Turn the Engine Switch to the ON position.
- Pull the starter grip lightly until you feel resistance; then pull briskly in the direction of the arrow as shown.

NOTE: Do not allow the grip to snap back after starting; return it gently to its original place.

Allow the engine to run for 15-30 seconds, then turn the Multi-switch to the RUN position.

Plug to the generator.

FOR MANUAL START:

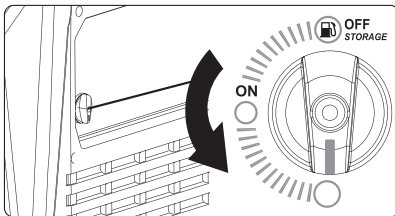
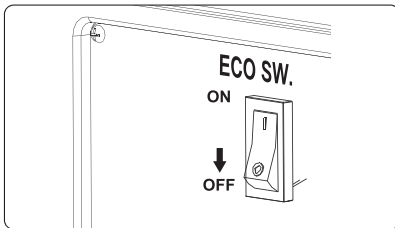
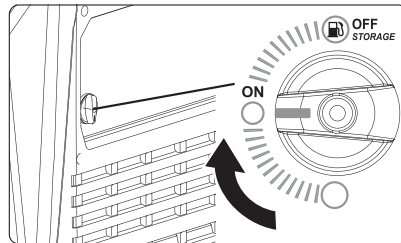
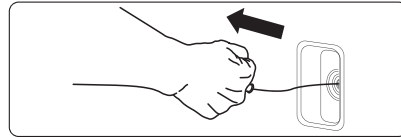
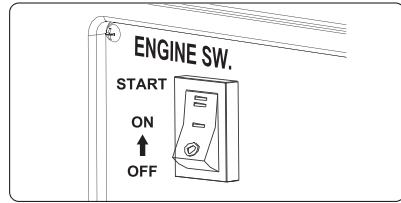

Stopping the Engine

- Remove any load from the generator.
- Turn the Engine Switch to the OFF position.
- Turn the Multi-switch to the OFF position.

To stop the engine in an emergency situation:

- Turn the Engine Switch to the OFF position.

FOR ELECTRIC START:

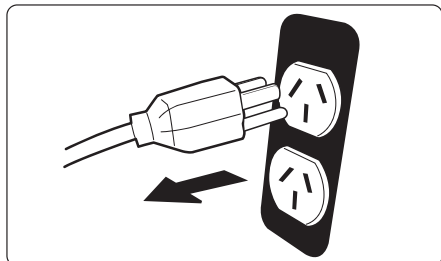
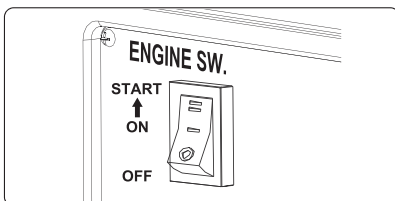

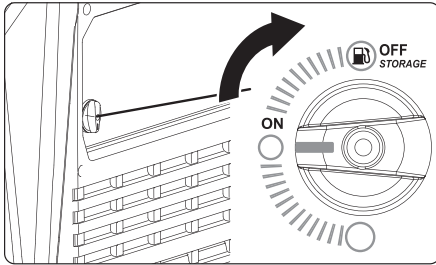
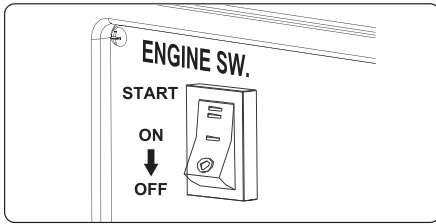
WARNING:

While operating and storing, keep at least 90cm of clearance on all sides of this product, including overhead. Allow a minimum of 30 minutes of “cool down” time before storage. Heat created by muffler and exhaust gases may be hot enough to cause serious burns and /or ignite combustible objects.

AC Applications

Before connecting an appliance or power cord to the generator:

- Make sure that it is in good working order. Faulty appliances or power cords can create a potential for electrical shock.
- If an appliance begins to operate abnormally, becomes sluggish, or stops suddenly, turn it off immediately. Disconnect the appliance, and determine whether the problem is the appliance or the rated load capacity of the generator has been exceeded.

Most appliance motors require more than their rated wattage for startup.

Make sure the electrical rating of the tool or appliance does not exceed the maximum power rating of the generator.

In either case, the total power requirements of all appliances connected must be considered. Appliance and power tool manufacturers usually list rating information near the model number or serial number.

Parallel Operation (Optional)

Before connecting an appliance to either generator, make sure that the appliance is in good working order and that its electrical rating does not exceed that of the receptacle.

Most motorized appliances require more than their electrical rating for startup. When an electric motor is started, the OVERLOAD indicator (red) may come ON. This is normal if the OVERLOAD indicator (red) goes OFF within 5 seconds. If the OVERLOAD indicator (red) stays ON, consult your generator dealer.

During parallel operation, the Eco switch should be in the same position on both generators.

Connect the parallel operation cable between two generators following the instructions supplied with the parallel kit.

OPERATION INSTRUCTIONS FOR TWO WIRE CONTROL

1 When the two wire control switch is pressed ON, one -key start, the remote control and ATS cannot control the start of the generator set. Only the two wire control socket(two-core aviation socket) can control the start and stop the generator set .Test the connection of the two-core aviation socket, the generator set is started, and the generator set is turned off when disconnected.

2 When the two wire control switch is pressed OFF,one -key start, the remote control and ATS can control the start of the generator set.But the two wire control socket cannot control the start and stop of the generator set.

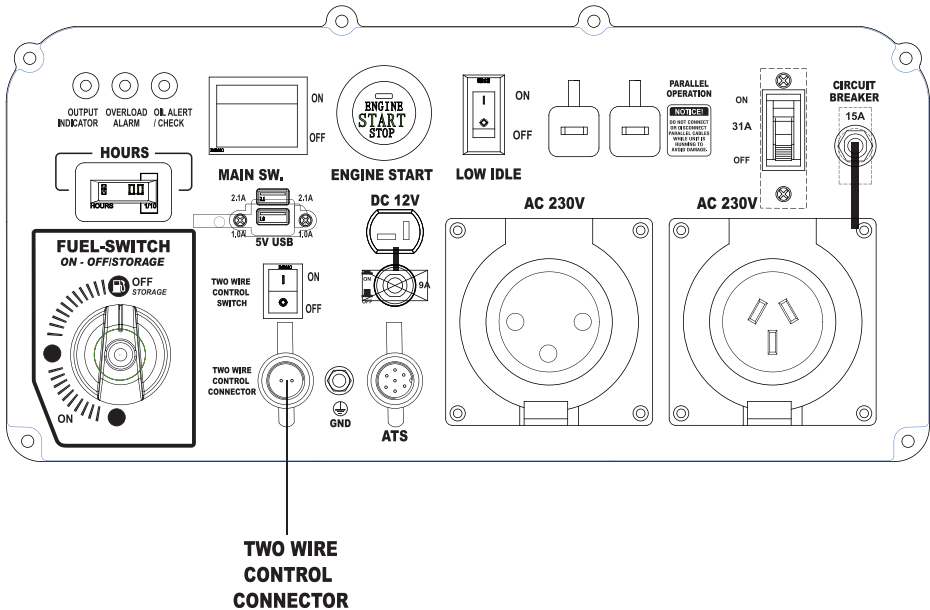

Standby Power

Connections to a Building's Electrical System

Connections for standby power to a building's electrical system must be made by a qualified electrician. The connection must isolate the generator power from utility power, and must comply with all applicable laws and electrical codes.

In some areas, generators are required by law to be registered with local utility companies. Check local regulations for proper registration and use procedures

WARNING:

Improper connections to a building's electrical system can allow current from the generator to backfeed into the utility lines.

Such backfeed may electrocute utility company workers or others who contact the lines during a power outage, and the generator may explode, burn, or cause fires when utility power is restored.

Consult the utility company or a qualified electrician prior to making any power connections.

High Altitude Operation

Specific modifications are needed for high-altitude operation. Please contact your authorized service center for important information regarding these modifications. Operating this engine without the proper altitude modification may increase the engine's emissions and decrease fuel economy and performance.

Maintenance

General Maintenance

WARNING:

When servicing, use only identical replacement parts. Use of any other parts could create a hazard or cause product damage.

Keep the generator in a clean and dry environment where it is not exposed to dust, dirt, moisture, or corrosive vapors.

Do not allow the cooling air slots in the generator to become clogged with foreign material such as leaves, etc.

Do not use a garden hose to clean the generator. Water entering the fuel system or other internal parts of the unit can cause problems that will decrease the life of the generator.

Checking/Cleaning Air Filter

For proper performance and long life, keep air filter clean.

- Loosen the screws at the side of the right maintenance cover. Remove cover and set aside.
- Unsnap the air filter cover clip, pulling the cover down and off the unit, remove air filter cover and set aside.
- Remove the air filter.
- Wash the air filters with warm, soapy water. Rinse and squeeze to dry.
- Reinstall the air filters.

NOTE: Make sure the filters are seated properly inside the generator. Installing the filters incorrectly will allow dirt to enter the engine, causing rapid engine wear.

- Reinstall the air filter cover.

- Reinstall the right maintenance cover. Tighten screws to secure.

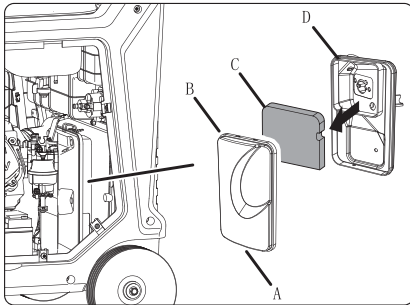
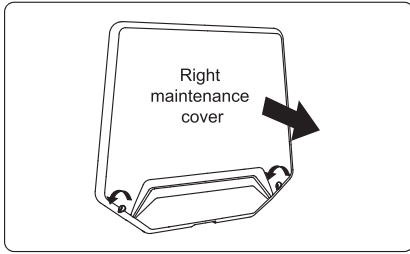

- Remove the oil fill cap/dipstick.
- Remove the other black rubber seal located in the front the oil drain plug.
- Use a wrench through the hole to remove the oil drain plug and allow the oil to drain completely.
- Reinstall the oil drain plug. Tighten the plug securely.
- Reinstall the two black rubber seal (the front one and the bottom one).
- With the generator in a level position and refill with engine oil following the instructions in the Checking/Adding engine oil section previously in this manual. For amount of engine oil needed to refill, see Product Specifications earlier in this manual or the accompanying engine manual, if applicable.
- Reinstall the oil cap/dipstick securely.
- Reinstall the left maintenance cover. Tighten screws to secure.

Changing Engine Oil

For best performance, engine oil should be changed after every 100 hours or 6 months of operation.

NOTE: Drain the engine oil while the engine is still warm but not hot. Warm engine oil will drain quickly and more completely.

- Loosen the screws at the side of the left maintenance cover. Remove cover and set aside.
- Reach under the generator and remove the black rubber seal located below the oil drain plug.
- Place a suitable container underneath the generator to catch the used oil.

NOTE: Used engine oil should be disposed of at an approved disposal site. See local retailer for more information.



WARNING:

Do not change engine oil while it is hot. Accidental contact with hot engine oil could result in serious burns.

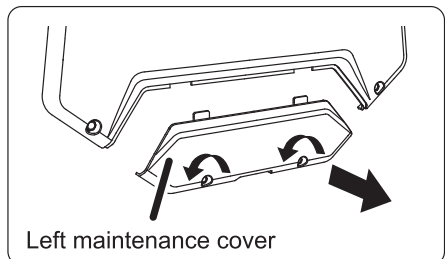

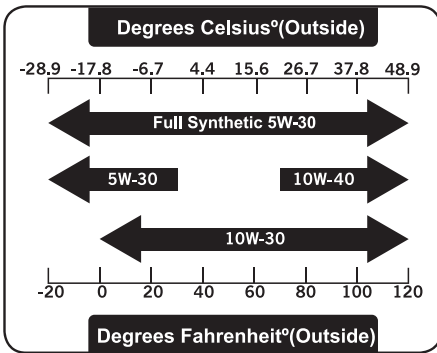
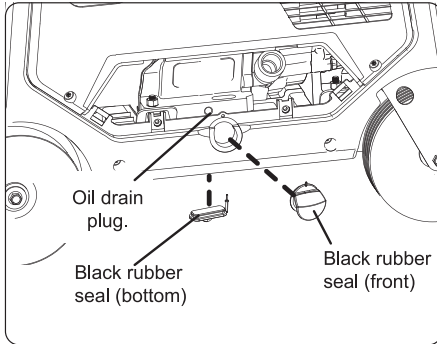

Spark Plug Replacement

The spark plug must be properly gapped and free of deposits in order to ensure proper engine operation. If the engine is hot, allow it to cool before servicing the spark plug.

- Loosen the screws at the side of the right maintenance cover. Remove cover and set aside.
- Remove the spark plug cap.
- Clean any dirt from around base of spark plug.
- Remove spark plug using spark plug wrench.
- Inspect the spark plug. Replace it if the electrode is worn or fouled, or if the insulator is cracked or chipped.

- Measure the spark plug electrode gap with a wire-type feeler gauge. Correct the gap, if necessary, by carefully bending the side electrode. The gap should be: 0.028-0.031 in (0.7-0.8mm)

- Seat spark plug in position; thread in by hand to prevent cross-threading.

If reinstalling a used spark plug, tighten 1/8-1/4 turn after the spark plug seats.

If installing a new spark plug, tighten 1/2 turn after the spark plug seats.

NOTE: An improperly tightened spark plug will become very hot and could damage the engine.

NOTICE:

Be careful not to cross-thread the spark plug. Cross-threading will seriously damage the product.

- Attach the spark plug cap.
- Close the right maintenance cover.

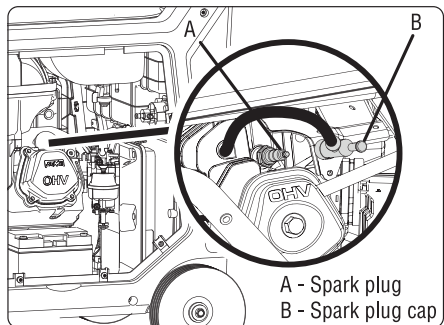
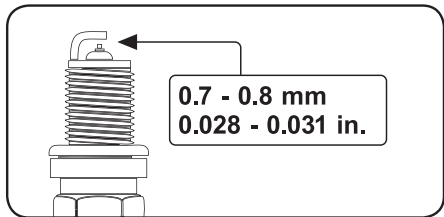

Spark Arrester Service

The spark arrester must be serviced every 100 hours to keep it functioning as designed.

If the engine has been running, the muffler will be very hot. Allow the muffler to cool before servicing spark arrester.

- Remove the two screws, and remove the tail pipe and spark arrester.
- Use a brush to remove carbon deposits from the spark arrester screen. Be careful to avoid damaging the screen.

The spark arrester must be free of breaks and tears. Replace the spark arrester if it is damaged.

- Install the spark arrester in the reverse order of removal.

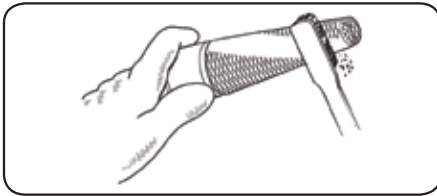

Draining Fuel Tank/ Carburetor

To help prevent gum deposits in the fuel system, drain the fuel from the tank and carburetor before storing.

Draining the fuel tank:

Remove the fuel tank cap, remove the fuel strainer, and empty the fuel tank into an approved fuel container. We recommend using a commercially available fuel hand pump to empty the tank. Do not use an electric pump. Siphon the petrol by inserting the tip of the hand pump into the side of the pump guard. Reinstall the fuel strainer and the fuel tank cap.

Draining the carburetor:

- Loosen the screws at the side of the right maintenance cover. Remove cover and set aside.
- Turn the Multi-switch to the RUN position.
- Position a suitable container under the carburetor drain screw to catch fuel; loosen the screw.
- Allow fuel to drain completely into container.
- Retighten drain screw securely.
- Turn the Multi-switch to the OFF position.

Transporting

- Turn the Multi-switch to the OFF position.
- Make sure engine and exhaust of unit is cool.
- Keep the generator level to reduce the possibility of fuel leakage.
- When using ropes or tie-down straps to secure the generator for transportation, be sure to only use the frame bars as attachment points. Do not fasten ropes or straps to any portions of the generator body or the folding transport handle.

Maintenance Schedule

NOTE: If a separate engine manual is provided for this generator, please follow the maintenance schedule provided in the engine manual instead of the maintenance information listed below.

	Before each use	After 1st month or 20 hours	Every 3 months or 50 hours	Every 6 months or 100 hours	Every year or after 300 hours
Check Engine oil	●				
Change Engine oil		●		●	
Check Air Filter	●				
Clean Air Filter			●		
Change Air Filter					●
Check/Adjust Spark Plug				●	
Replace Spark Plug					●
Check/Adjust Idle Speed					●
Clean Fuel Tank & Filter				●	
Check Fuel Hose	●				
Fuel Filter	Inspect				Replace
Check/Adjust Valve Clearance					●
Clean Spark Arrester				●	

NOTE: Maintenance should be performed more frequently when generator is used in dusty areas.

When generator has exceeded the maximum figures specified in the table, maintenance should still be cycled according to the intervals of time or hours stated herein.

Storage

Storage Guidelines

When preparing the generator for storage, allow the unit to cool for 30 minutes then follow the guidelines below.

STORAGE TIME	PRIOR TO STORING
Less than 2 months	<ul style="list-style-type: none"> ■ Drain petrol from tank and dispose of in a suitable container according to state and local ordinances.
2 months to 1 year	<ul style="list-style-type: none"> ■ Drain petrol from tank and dispose of in a suitable container according to state and local ordinances.
1 year or more	<ul style="list-style-type: none"> ■ Remove spark plug. ■ Drain petrol from tank and dispose of in a suitable container according to state and local ordinances. ■ Put a tablespoon of engine oil into the spark plug cylinder. Turn the engine slowly with the pull rope to distribute the engine oil. ■ Reinstall spark plug. ■ Change engine oil. ■ After removal from storage, fill with fresh petrol.
<p>NOTE: If storing petrol in suitable container for later use, make sure petrol has been treated with fuel stabilizer according to stabilizer manufacturer's instructions.</p>	

Troubleshooting

Engine will not start:

Possible Cause	Solution
Battery not charged.	Charge battery.
Engine switch is in the OFF position.	Turn engine switch to the ON position.
No fuel.	Fill fuel tank.
Stale petrol or water in petrol	Drain entire system and refill with fresh fuel.
Engine oil level is low.	Engine is equipped with Low Oil Shutoff. If engine oil level is low, it must be filled before unit will start. Check engine oil level and fill, if necessary.
Multi-switch is in OFF or Run position.	Turn multi-switch to the START position.
Spark plug faulty, fouled, or improperly gapped.	Replace spark plug.
Engine stored without treating or draining petrol, or refueled with bad petrol.	Drain fuel. Refuel with fresh petrol.
Dirty fuel filter.	Replace fuel filter or contact a qualified service center.

Engine lacks power:

Possible Cause	Solution
Dirty air filter.	Check air filter element. Clean or replace as needed.
Engine stored without treating or draining petrol, or refueled with bad petrol.	Drain fuel. Refuel with fresh petrol. If problem continues, contact a qualified service center.

AC Receptacle does not work:

Possible Cause	Solution
OUTPUT indicator is OFF, and OVERLOAD indicator is ON.	Check AC load. Stop and restart the engine. Check the cooling air inlet. Stop and restart the engine.
AC Circuit protector(s) tripped.	Check AC load and reset AC circuit protector(s)
GFCI system activated.	Reset the GFCI. (Ground Fault Circuit Interrupter)
Item plugged in is defective.	Try a different item.

If problem persists after trying the above solutions, contact your nearest authorized service center for assistance.

Parts

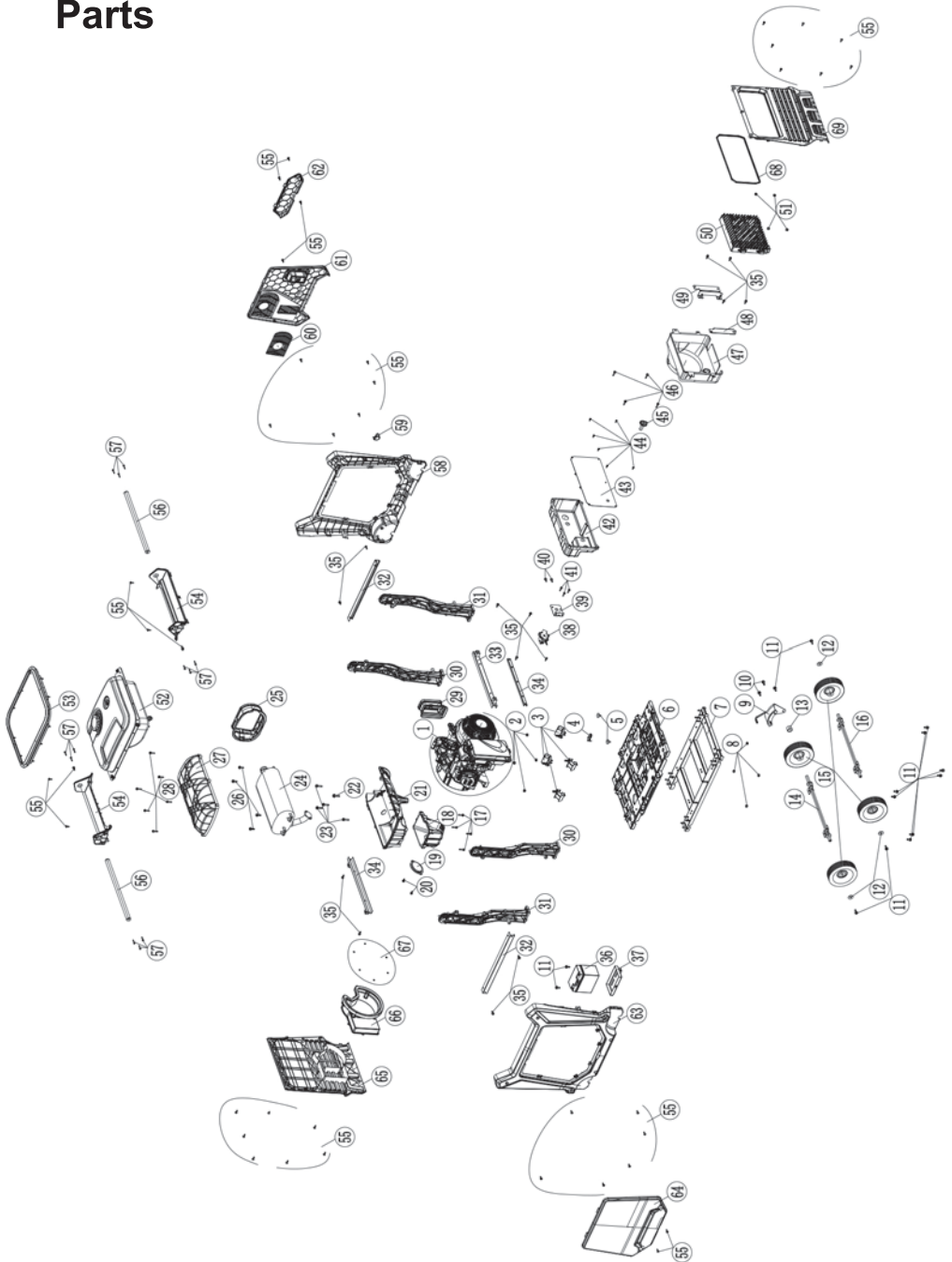

Parts List

ITEM	ITEM NAME	QTY
1	ENGINE	1
2	NUT M10*1.25	4
3	ISOLATOR	4
4	BLACK RUBBER SEAL (BOTTOM)	1
5	ISOLATOR, INVERTER	2
6	BASEBOARD	1
7	SUPPORT, FRAME	1
8	NUT M8*1.25	20
9	WHEEL LOCK ASSEMBLY	1
10	BOLT M8*1.25	2
11	BOLT M8*1.25	18
12	WASHER	3
13	BUSHING	1
14	AXLE	1
15	WHEEL/TYRE ASSEMBLY	4
16	AXLE	1
17	BOLT M6*1	4
18	CONNECTION PLATE	1
19	COVER, CONNECTION PLATE	1
20	BOLT M6*1	2
21	BOTTOM COVER, MUFFLER	1
22	BOLT M10*1.25	1
23	BOLT M8*1.25	4
24	MUFFLER	1
25	SIDE COVER, MUFFLER	1
26	BOLT M8*1.25	4
27	TOP COVER, MUFFLER	1
28	BOLT M6*1	10
29	EXHAUST COVER, MOTOR	1
30	SUPPORT A	2
31	SUPPORT B	2
32	BEAM, RIGHT AND LEFT	2
33	BEAM, FRONT AND BACK	2
34	BEAM, LOWER FRONT	1
35	BOLT M6*1	14

ITEM	ITEM NAME	QTY
36	BATTERY	1
37	SUPPORT, BATTERY	1
38	BODY, MULTI-SWITCH	1
39	MULTI-SWITCH MOUNTING PLATE	1
40	BOLT M6*1	3
41	SCREW M5	3
42	PANEL REAR COVER	1
43	PANEL	1
44	SCREW M5	6
45	MULTI-SWITCH	1
46	BOLT M6*1	4
47	BACK COVER, INVERTER	1
48	LEFT SUPPORT, INVERTER	1
49	RIGHT SUPPORT, INVERTER	1
50	INVERTER ASSEMBLY	1
51	NUT M6*1	5
52	FUEL TANK	1
53	SEALING STRIP	1
54	TOP COVER	2
55	BOLT M6*1	38
56	HANDLE	2
57	SELF-TAPPING SCREW M5*25	12
58	RIGHT COVER	1
59	BLACK RUBBER SEAL (FRONT)	1
60	HEAT SHIELD, MUFFLER	1
61	RIGHT SHIELD	1
62	RIGHT MAINTENANCE COVER	1
63	LEFT COVER	1
64	LEFT MAINTENANCE COVER	1
65	BACK COVER	1
66	VENTILATION HOOD, MOTOR	1
67	RETAINING RING	6
68	SEALING STRIP, PANEL	1
69	FRONT COVER	1

Warranty

As part of an on-going commitment to excellence in product support, Euroquip offers a comprehensive product warranty program.

1. THIS WARRANTY:

The benefits provided to the consumer in this warranty are in addition to other rights and remedies of a consumer under the New Zealand Consumer Guarantees Act 1993 and any other laws in relation to the products to which this warranty relates. This warranty:

- Covers the product against faulty materials or workmanship; and
- Covers the replacement of parts, the repair labour used, a refund of the price of the product or replacement of the machine, or other compensation for the remainder of the warranty period.

This product warranty is only applicable to the original purchaser of the machine and only purchases made from Euroquip Authorized Retailers.

2) WARRANTY PERIODS:

Commercial Warranty*: 2 Years (24 months)
Domestic Warranty* : 4 Years (48 months)

Domestic Warranty applies to domestic use of the product: Personal, residential, or household use only. Commercial Warranty applies to commercial or business use of the product: All uses other than domestic use, including use for income-producing (including farming) or rental purposes.

*These GT Power Warranty periods are for products that are:

- Purchased from a New Zealand GT Power Dealer after 01/06/23
- Serviced by a GT Power Dealer in accordance with the GT Power service schedule, using genuine parts and the correct grade of oil (proof required)
- Meeting all other warranty requirements

NOTE: These warranty conditions apply to New Zealand only.

Euroquip warrants each new GT Power machine free from defect in material and workmanship under normal use and routine servicing, for the warranty periods specified. Conditional to the limitations and exclusions list below. The warranty period begins when the product is purchased by the end user. Warranty is not transferrable and is only claimable by the original purchaser.

Proof of purchase documentation with product serial number must be provided. If it has been lost and Euroquip does not have a record of the purchaser's details, the warranty period shall be calculated from the appropriate dealer wholesale sale date.

The purchaser must keep a record of all service and maintenance history as proof of servicing history. This may be requested when assessing any future warranty claims. The decision that an issue with a product qualifies as a warranty claim is made at the sole jurisdiction of Euroquip.

No costs incurred will be considered under warranty if repairs or maintenance are carried out by any party other than a Euroquip Approved Service Agent, unless with prior consent in writing from Euroquip.

It is the full responsibility of the purchaser to deliver the product under warranty to the nearest relevant service agent or product reseller. Warranty does not cover transportation costs including call outs, mileage and freight costs.

Customers are responsible for the care and cleaning of their product prior to sending it to our service centre. Any product being sent us must be thoroughly cleaned. Depending on what the product has come into contact with, it could pose an Occupational/ Work Health and Safety risk for our staff and/or service agents to inspect, repair or service a product that has come into contact with a hazardous substance. If we are asked to inspect, repair or service a product that has come into contact with a hazardous substance such as chemicals, asbestos or silica dust, we may not be able to inspect, service or repair the product. If this is the case, we will inform the purchaser and the product will be returned.

If a product is repaired under warranty, parts and labour required for the repair will be supplied at no charge. All defective parts replaced under warranty become property of Euroquip. Consumable items such as, but not limited to, oils, coolants, filter and spark plugs shall be the responsibility of the owner. Warranty assessment and repair will be scheduled and executed according to the normal work flow at the service location and depending on the availability of suitable replacement parts.

This warranty policy is an additional benefit and does not supersede the legal rights of any customer, reseller or service agent.

Should any issue be found to be a combination of a warranty failure and a non-warranty issue such as incorrect charging techniques, the repair cost component to rectify and repair the non-warranty failure is the **customer's** full responsibility.

3) EXCLUSIONS:

- Warranty does not cover parts that are subject to wear and tear from usage and/or damage which results from neglect of periodic maintenance.
- Evidence must be provided that the product has been maintained and serviced suitably for a claim to be considered under warranty.
- Batteries supplied with your product are warranted against defect for 3 months and does not include lack of charge due to non-use. Consumable items such as, but not limited to, oils, coolants, filters, spark plugs and batteries shall be the responsibility of the purchaser.
- Failure caused by incorrect operation of the product as specified in the manual either intentionally or by error.
- Lack of proper care and maintenance of the product.
- Any damage which results from unavoidable natural disasters, fire, collision, theft, etc.
- Any normal wear or deterioration, such as that of sliding or rotating parts caused under normal operating conditions.
- Any damage that results from misuse or use beyond the imitations of the products intended purpose (such as overloading or use under abnormal conditions).
- External circumstances such as product deterioration or corrosion due to environmental conditions like heat, cold, salt spray, sand or due to the passage of time
- Normal phenomena such as noise, vibration or oil seepage which are considered by Euroquip as not affecting the quality, function or performance of the product.
- Any damage due to improper storage or transport.
- Consumable replacement items: Spark plugs, contact points, shear pins, fuel strainers, oil filter elements, air cleaner elements, brake shoes or pads, clutch components, fuses, motor brushes, gaskets, tube or hoses, belts, cutting blades, light bulbs, serviceable bearings. Petroleum and others fluids: Oil, grease, battery electrolyte, and radiator coolant. Other items specified by Euroquip.
- Periodical maintenance items such as cleaning, inspection and adjustments.
- Contaminated fuel
- Modifications or installations of other products to the product
- Damage that results from the use of non-genuine parts, lubricant or fluid not approved by Euroquip
- Any repair and/or adjustment to correct improper or poor quality work previously performed.
- Attempted repair/ service by a party other than an Approved Service Agent, or any repair undertaken prior to approval of warranty be Euroquip is not covered under warranty.
- Warranty does not cover pre delivery service and adjustment, or failure that may occur as a result of lack of/ incorrect pre delivery service and adjustment. Warranty does not cover any incidental, indirect or consequential loss, damage, personal injury, or expense that may result from any defect, failure, malfunction, or misuse of a product.
- Any product that is found to have come into contact with hazardous substances such as chemicals, asbestos or silica dust and NOT been industrially cleaned prior to servicing.

4) HOW TO CLAIM WARRANTY:

In the event you are faced with a manufacturing fault with your GT Power product, you can claim a repair or part replacement under warranty if the following conditions are fulfilled:

- The problem is related to production quality or specifications of the machine
- The machine is within the warranty period outlined in schedule
- The issue does not fall within the warranty exclusions listed

If the criteria above is met, and you would like to request a warranty, then please go online to <https://www.euroquip.co.nz/Service-Request-End-User> and log your warranty claim.



GT8000ESi ELECTRIC START INVERTER GENERATOR



Congratulations on your new GT POWER product. We are proud to have you as our customer and will strive to provide you with the best service and reliability in the industry. This product is backed by our extensive warranty and service network. To locate your nearest distributor or service agency visit www.euroquip.co.nz or email us at customerservice@euroquip.co.nz.